



**HISTORIC PRESERVATION BOARD STAFF REPORT**

**Sundy Village**

Meeting	File No.	Application Type
September 4, 2024	2024-162	Certificate of Appropriateness and Master Sign Program

**REQUEST**

The item before the Board is consideration of establishing a Master Sign Program (2024-162) for the development known as **Sundy Village within the Old School Square Historic District.**

**GENERAL DATA**

**Owner:** Sundy Village West, LLC  
**Agent:** Jared Hochman  
**Location:** 25 SW 1<sup>st</sup> Avenue  
**PCN:** 12-43-46-16-Q6-001-0020  
**Project Name:** Sundy Village  
**Project Size:** 6.902 Acres  
**Project Zoning:** OSSHAD, OSSHAD w/ CBD Overlay  
 LUM: HMU (Historic Mixed Use)  
**Historic District:** Old School Square Historic District  
**Adjacent Zoning:**

- North: OSSHAD, OSSHAD w/ CBD Overlay
- East: OSSHAD, CBD
- South: CF, OSSHAD
- West: CF, CBD, RM

**Existing Land Use: Commercial**  
**Proposed Land Use: Commercial**



**BACKGROUND**

The subject property includes all of Block 61, a portion of the Sundy and Cromer block, and portions of Blocks 69 & 70. The properties associated with the subject development proposal are zoned Old School Square Historic Arts District (OSSHAD) and are located within the locally and nationally designated Old School Square Historic District. That portion of the project that fronts on West Atlantic Avenue and the proposed hotels that front on SE 1<sup>st</sup> Avenue are subject to the development standards of the Central Business District (CBD). The Sundy House property contains several structures including the Sundy House, and several 2-story structures, the property is listed on the National Register of Historic Places. There are 7 contributing structures within Block 61 and several non-contributing structures, 4 contributing structures within Block 70, and a contributing structure and accessory building within Block 69.

In 1998, a conditional use request was approved by the City Commission for Sundy House (Lots 1-3, Sundy Estates Subdivision) and included 11 Residential-Type Inn units. The Class V Site Plan for the

<b>Project Planner:</b> Katherina Paliwoda, Historic Planner, paliwodak@mydelraybeach.com Michelle Hoyland, Principal Planner, hoylandm@mydelraybeach.com	<b>Review Dates:</b> HPB: September 4, 2024	<b>Attachments:</b> 1. Sign Program 2. Program Table
---	--	--

Sundy House and Inn was approved by the HPB on March 18, 1998. Also approved by HPB in 1998, was relocation of a 1948 brick structure from the Sundy House and Inn property to a lot along 131 NW 4<sup>th</sup> Avenue in the West Settlers Historic District. The structure is occupied by the Williams family, Mr. Williams was a carpenter who worked on its original construction in 1948.

At its April 4, 2007, meeting, HPB considered a conditional use request to expand the residential-type inn use within the Sundy House property located on Block 62 and establish the residential-type inn use within Blocks 61 and 70, located to the north and east, respectively. The request would have placed a total of 87 units within the development. The City Commission approved the request at its meeting of May 1, 2007. However, the units were never built, and the approval expired.

At their meeting of October 17, 2016, the Planning & Zoning Board recommended approval of Alley Abandonments (2016-080) within Block 61.

At their meeting of June 26 & 27, 2017, the Historic Preservation Board reviewed & approved a Conditional Use (2016-102) request to allow 39 additional Residential-type Inn units (11 existing associated with the Sundy House). The board denied the Class V Site Plan, Certificate of Appropriateness, Landscape Plan, Architectural Elevations, & Waivers (2016-073) for Swinton Commons that included: 35,049 square feet of retail; 22,525 square feet of restaurant; 21,872 square feet of office; 44 dwelling units; 39 residential-type inn units; and 109 hotel rooms. Specifically, the Waiver relief requests were to allow an increase in the 60' maximum building width fronting a street to 163', 135', and 71'. The project also included the relocation of seven of the existing contributing buildings, reconstruction of one existing building, and demolition of nine buildings. The board approved relocation of 3 structures (21 SW 1st Avenue; 44 S. Swinton Avenue - Bldg. G; and, 6 SE 1st Street - Building H) and approved demolition of 7 structures (52 W. Atlantic Avenue - Building T; 20 W. Atlantic Avenue - Building U; 35½ SW 1st Avenue - Building V; 14 SE 1st Street - Building W; 18 SE 1st Street - Building X; 18½ SE 1st Street - Building Y; and, 48 SE 1st Avenue - Building Z). The board denied relocation of 5 structures (14 S. Swinton Avenue - Building A; 20 W. Atlantic Avenue; 22 S. Swinton Avenue; 38 S. Swinton Avenue - Building E; and, 40 S. Swinton Avenue - Building F) and denied demolition of 2 structures (44 S. Swinton Avenue - Building G-ACC and 38½ S. Swinton Avenue - Building E1).

At their meeting of July 17, 2017, the Planning & Zoning Board recommended approval of the Conditional Use (2016-101) request for the addition of 39 Residential-type Inn units (50 total on-site including the 11 existing on the Sundy House portion of the site) subject to conditions and of the abandonment of an alley within Block 69, subject to conditions.

Then, at their meeting of December 19, 2017, the Historic Preservation Board reviewed and denied a modified request for a Class V Site Plan, COA, Landscape Plan, Elevations, Waiver, Demolitions, & Relocations for the project, which was renamed Midtown Delray. The proposal included includes 39,396 square feet of retail; 11,117 square feet of restaurant; 55,218 square feet of office; 45 dwelling units; and 39 residential-type inn units. The proposal includes the relocation of seven of the existing contributing buildings & reconstruction of one existing building and demolition of 2 structures. Finally, the request also included waivers, to allow a reduced rear setback for Building 1 and to allow an increase to the maximum width of a building fronting a street for several structures.

Following HPB's December 2017 denial of the Midtown Delray requests, the applicant appealed the denials to the City Commission. The request was heard at the February 6, 2018, City Commission meeting and following a lengthy meeting the applicant requested a postponement in order to make

modifications to the development proposal to address concerns including the elimination of requested waivers relating to building width and rear setbacks.

Then, at their meeting of March 6, 2018, the City Commission approved the modified Class V Site Plan, Certificate of Appropriateness, Landscape Plan, Architectural Elevations, Demolitions, Relocations, Waivers, Conditional Use, and alley abandonments within Block 69 and Block 61, subject to conditions. Specifically, the approval included the following:

- Conditional Use request to allow an additional 24 Residential-type Inn units in association with the Sundy House (1 additional unit at the Sundy House, 9 new units on Block 61, and 14 new units on Block 70 – overall project total of 35 residential-type inn units including the 11 existing units at the Sundy House);
- Construction of 38,160 square feet of retail; 11,117 square feet of restaurant; 70,597 gross square feet of office (60,594 net sq. ft.); 45 condominium dwelling units; and 24 additional residential-type inn units. Also, included in the approval are underground parking garages, the largest within the Block 61 portion of the site and a smaller garage within the Block 69 portion of the site.
- Waivers to LDR Section 4.4.24(F)(4) to allow building widths of 71' 6", and 81' 4", where a maximum width of 60' is permitted in the Old School Square Historic Arts District (OSSHAD) for Building 3 and the Building 6/7 within Block 70 (southeast corner of S. Swinton Avenue & SE 1<sup>st</sup> Street).
- Relocation of 7 existing contributing structures, with 6 of the relocations within Block 61 (along Swinton Avenue) and the 7<sup>th</sup> structure being moved from Block 61 to the Sundy House property:
  - 14 S. Swinton Avenue – Building A “The Rectory”
  - 20 W. Atlantic Avenue – Building B
  - 22 S. Swinton Avenue – Building C
  - 21 SW 1<sup>st</sup> Avenue – Building D
  - 38 S. Swinton Avenue – Building E “Cathcart House”
  - 40 S. Swinton Avenue – Building F “Peach House”
  - 44 S. Swinton Avenue – Building G “Yellow House”
- Demolition of 9 structures, including the reconstruction of one structure from Block 70 on the Sundy House portion of the site to the west:
  - 38 1/2 S. Swinton Avenue – Building E-1
  - 44 1/2 S. Swinton Avenue – Building G-ACC
  - 10 SE 1<sup>st</sup> Street – Building H “White House” (Reconstruction)
  - 52 W. Atlantic Avenue – Building T
  - 20 W. Atlantic Avenue – Building U
  - 35 1/2 SW 1<sup>st</sup> Avenue – Building V
  - 14 SE 1<sup>st</sup> Street – Building W
  - 18 SE 1<sup>st</sup> Street – Building X
  - 18 1/2 SE 1<sup>st</sup> Street – Building Y
  - 48 SE 1<sup>st</sup> Avenue – Building Z
- Abandonment of an improved east/west alley within Block 69.
- Abandonment of an improved east/west and north/south alley in Block 61.
- Construction of a pedestrian plaza within Block 61, replacing the abandoned north/south alley.
- Construction of a vehicular drop-off area.
- Installation of new landscaping and hardscaping.

The approved/certified plan included conditions of approval:

1. That the locations of the generators are provided on the plans together with the source of fuel prior to certification of the site plan.
2. That the site plan be revised to correctly note the required parking of 379 parking spaces prior to certification of the site plan.

3. That the fourth floor of buildings #1 and #2 be eliminated, that the third floor can be moved forward 12 feet. The applicant may add a third floor to building #3.
4. That the applicant enter into a community benefits agreement with the City of Delray Beach that includes items such as a jobs program/fair, mentorship, and a \$100,000 grant for the historic preservation grant prior to issuance of the first vertical building permit.
5. That the applicant submit a restrictive covenant to commence construction within two years of approval for Block 61 to be approved by the City Attorney prior to issuance of the first building permit. That the restrictive covenant include a performance bond of \$1,000,000 for this requirement for Block 61, which is to be forfeited for failure to commence construction.
6. That the applicant provide significant evidence that the use operate as a residential-type inn.

At its January 5, 2022, meeting, the Historic Preservation Board (HPB) made a recommendation of approval to the Planning and Zoning Board for a Conditional Use request to allow 2,000 sq. ft. of outdoor dining at night for restaurants within Buildings 1 & 2 within Lots 1-4, Block 61 of the Sundy Village Project. The HPB also recommended approval to the City Commission of a Waiver request to CBD Frontage Type standards to allow the use of the Porch frontage type instead of a Storefront frontage type, along W. Atlantic Avenue, which is a required retail frontage street. At their January 24, 2022, meeting the Planning and Zoning Board recommended approval of the Conditional Use to City Commission.

The City Commission approved the Conditional Use (Resolution No. 03-22) and the Waiver to the CBD Frontage Type standards (Resolution No. 04-22) at their meeting of February 8, 2022. The City Commission also approved Resolution No. 25-22 which establishes a sequence of events in the development process to meet current conditions of approval for the approved/certified project in a workable framework. Specifically, relating to the construction of an alley, platting, and demolition of a structure within Block 69. The combination of conditions of approval and code direction did not allow for the plat to be recorded until the new alley in Block 69 is built, building the alley requires demolition of Building Z, Building Z cannot be demolished without a building permit for new construction, which cannot be issued without the plat being recorded. Resolution No. 25-22 resolved these conflicts.

At its meeting of March 2, 2022, HPB approved a Class III Site Plan Modification, Certificate of Appropriateness, Landscape Plan, Architectural Elevations, Variances, & Relocations request as follows:

- Construction of 14,230 sq. ft. retail use, 21,375 sq. ft. restaurant use (2,000 sq. ft. - outdoor dining), 105,027 gross sq. ft.(69,850 net sq. ft.) office use, 45 residential condominium units, 15 Residential-type Inn units (26 units total - 12 within the Sundy House portion of the site and 14 within Building 6/7 located on Block 70), an underground parking garage (Block 61). The total project will contain 253,336 sq. ft. gross square foot of building area including existing structures and common areas/net square foot areas. Below is a table summarizing the approved and proposed use intensity/density changes:

USE	UNIT	APPROVED/CERTIFIED PLAN	PROPOSED	CHANGE
RETAIL	SF	38,160	14,230	<b>(23,930)</b>
RESTAURANT	SF	11,117	21,375	<b>10,258</b>
OFFICE	SF	70,597 Gross 60,694 Net	105,027 Gross 69,850 Net	<b>34,465 Gross</b> <b>9,156 Net</b>
RESIDENTIAL	DU SF	45 80,990 SF	45 80,990 SF	<b>NO CHANGE</b>
RESIDENTIAL TYPE INN	UNITS SF	35 (24 New & 11 Existing) 46,444	26 (15 New & 11 Existing) 29,074	<b>(9)</b> <b>(17,370)</b>
MECH. BLDG.	SF	UNKNOWN	2,640	<b>UNKNOWN</b>

ELEVATORS				
TOTALS	SF	247,308 Gross 237,405 Net	253,336 Gross 218,159 Net	6,028 Gross (19,246) Net

- Modification of the approved architectural style of the new structures within Block 61.
- Construction of a 2,272 sq. ft. Mechanical Equipment Yard/Building and other accessory structures such as elevator service buildings.
- Modification of the approved relocations of Building A, C, E, & F
- Variances to reduce the front yard setbacks from 25' to 20' for Buildings C & F
- Modification of the approved landscaping and hardscaping.
- Construction of a pedestrian plaza within Block 61, replacing the abandoned north/south alley.
- Construction of a vehicular drop-off area.
- Construction of new on-street public parking spaces.

At its meeting of January 4, 2023, HPB approved a Certificate of Appropriateness (2023-015) request for exterior modifications to the Sundy House. The specific requests are listed below:

- Removal of the existing non-contributing open-air gazebo, covered walkway, and reception area additions.
- Change the material of the existing vinyl/canvas awning to steel and glass for the non-contributing addition to the rear of the original structure.

At its meeting of November 1, 2023, HPB approved a Certificate of Appropriateness and Relocation (2023-181) request for the Cathcart House, primarily for structure stability purposes, as follows:

- Temporary Relocation of the existing structure vertically by 5' in place in order to install a new stem wall foundation;
- Construction of a new foundation;
- Installation of new 1<sup>st</sup> floor support joists;
- Removal of the existing, non-original concrete wrap around first floor porch deck; and
- Construction of a new first-floor, wood wrap around porch deck.

On December 6, 2023, HPB approved architectural modifications to Buildings 9-North (9N), 9-South (9S), 8-North (8N), 8-West (8W), and 8-South (8S) located on Block 61. These included the following modifications:

Buildings 8N, 8W, and 8S

- Enlargement of buildings on the east/west sides from the approved 42'2" to 44'2".
- Removal of the two Juliette style balconies with awnings on the west side of Building 8W and the east sides of Buildings 8S and 8N to be replaced with shutters.
- Change to the exterior stair orientations on the west sides of Buildings 8N and 8S, and the east side of Building 8W to accommodate the required Fire Code distance between stairs.
- Double doors on the third floor replaced with a single door on the east elevations of Buildings 8S and 8N.
- Double doors replaced with a single door on the ground floor west elevations of Buildings 8N and 8S.
- Shutters are added to the third-floor windows and doors on the north and south elevations of Buildings 8N, 8W, and 8S to be consistent with the other elevations.
- All operable windows changed to fixed on all Buildings 8N, 8W, and 8S elevations.
- Landscape and hardscape modifications to the southwest sides of Building 8W along SW 1<sup>st</sup> Avenue and SW 1<sup>st</sup> Street.

### Buildings 9N and 9S

- Grille removed from the ground floor stair exit doors on the north and south elevations of Building 9S.
- The arch design removed from the top of door on southwest elevation of Building 9S and the northeast elevation of Building 9N with an awning to match the door on the north elevation of Building 9S.
- Doors and windows on the ground floor of the north elevation of Building 9N to match changes with Building 9S.
- All operable windows changed to fixed on all Building 9N and 9S elevations.
- Landscape and hardscape modifications to the west side of Buildings 9N and 9S along SW 1<sup>st</sup> Avenue.

### Mechanical Yard Building

- Increase the height and width of the overhead door on the west elevation of the mechanical yard building to accommodate enlargement of the trash compactor.
- Generator door on the south elevation of the mechanical yard building removed due to the relocation of the generator.
- Change in roof style on the south and east elevations of the mechanical yard building to accommodate the relocation of the generator and enlargement of the trash compactor.

At its meeting of January 31, 2024, HPB approved the Level 3 Site Plan, Certificate of Appropriateness, Landscape Plan, Architectural Elevations, Variance, and Waivers (2023-253) request for a change of use and exterior modifications to structures within Blocks 61, 69, and 70.

At its meeting of March 6, 2024, a temporary relocation was approved by HPB for the existing structure vertically elevated by 5' in place in order to install a new stem wall foundation, for the structure to then be lowered back onto the new foundation.

On May 1st, 2024, the HPB approved landscape modifications and a hardscape modification to the previously approved fountain/water feature located in the civic plaza located between Buildings 1 and 2 on Block 61 of the Sundy Village site.

## **PROJECT DESCRIPTION**

The proposed Master Sign Program includes 20 free standing signs, at least 21 projecting signs, 9 directional signs, 2 directory, 9 historic signage, at least 32 nameplates, at least 18 wall signs, and at least 12 instructional signs, for the Sundy Village development. The program incorporates two different font types between those classified as historic signage and those not. The color and material palate includes Cast Bronze, Flower White colors with Coquina/Coralina stone, stucco, and vinyl materials.

**SUNDY VILLAGE - Graphic Standards**

STANDARD FINISHES

MP07458 CAST BRONZE  
MATTHEWS PAINT

Tenant Letters/Wayfinding

ADDRESS NUMBERS  
PAINTED MP07458 CAST BRONZE

ADA Sign Background

ADA Copy

Material Reference  
To be faux finish

**GENERAL NOTE:**  
 ALL SIGNAGE NOT TO EXCEED STANDARD  
 CODE SQUARE FOOTAGE REQUIREMENTS

CENTURY GOTHIC  
 ABCDEFGHIJKLMNOP  
 QRSTUVWXYZ1234567890

PANAGRAM MEDIUM  
 ABCEDFGHIJKLMNOP  
 QRSTUVWXYZ0123456789

MONUMENT SIGN FACES  
CORALINA OR COQUINA  
STONE

EXAMPLE OF SIGNS  
FOR CAST PLAQUES

Vinyl Copy

DIRECTORY SIGN FACES  
SMOOTH STUCCO FINISH  
TO MATCH SW7102 FLOWER WHITE

**Block 61**

**Wall sign (1) - Garage**

**Sign Location:** Internal to the site. Entrance to the underground parking garage.

**Proposed height:** 30"

**Proposed width:** 183"

**Proposed sign Area:** 38.1 sq. ft.

**Material and Color:** Painted "Cast bronze" with white LEDS (backlit) illuminated.



**Wall signs (17) – Tenant Name**

**Sign Location:** 3 facing W. Atlantic Avenue, 2 at the corner of W. Atlantic Avenue & S. Swinton Avenue, 1 facing S. Swinton Avenue, 3 facing SW 1<sup>st</sup> Avenue, 1 at the corner of W. Atlantic Avenue & SW 1<sup>st</sup> Avenue, and 7 Internal to the site.

**Proposed height:** Ranges between 8-1/2” to 16”

**Proposed width:** Ranges between 78” to 143”

**Proposed sign Area:** 4.9 sq. ft. to 15.9 sq. ft.

**Material and Color:** Painted “Cast bronze” with white LEDS (backlit) illuminated.

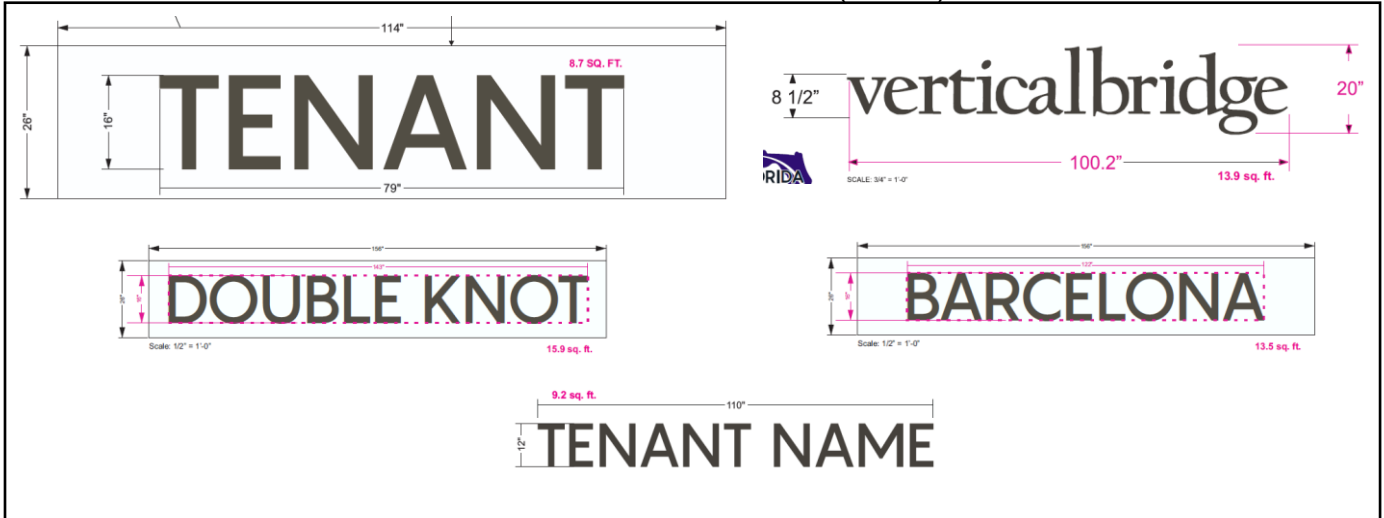

**Instructional signs (11) (1 – Do Not Enter & 11 – No Smoking)**

**Sign Location:** Do not Enter - Entrance to the underground parking garage (for pedestrians). No Smoking – 2 along W. Atlantic Avenue, 2 at the corner of W Atlantic Avenue & S. Swinton Avenue, 2 along S. Swinton Avenue, corner of W Atlantic Avenue & SW 1<sup>st</sup> Avenue, and 4 internal to the site.

**Proposed height:** Ranges between 4” to 6”

**Proposed width:** Ranges between 6” to 8’

**Proposed sign Area:** .02 sq. ft. to 2.6 sq. ft.

**Material and Color:** Do Not Enter - Painted “Cast bronze” with white vinyl & No Smoking – Painted “Cast Bronze” with oxidized border and text.

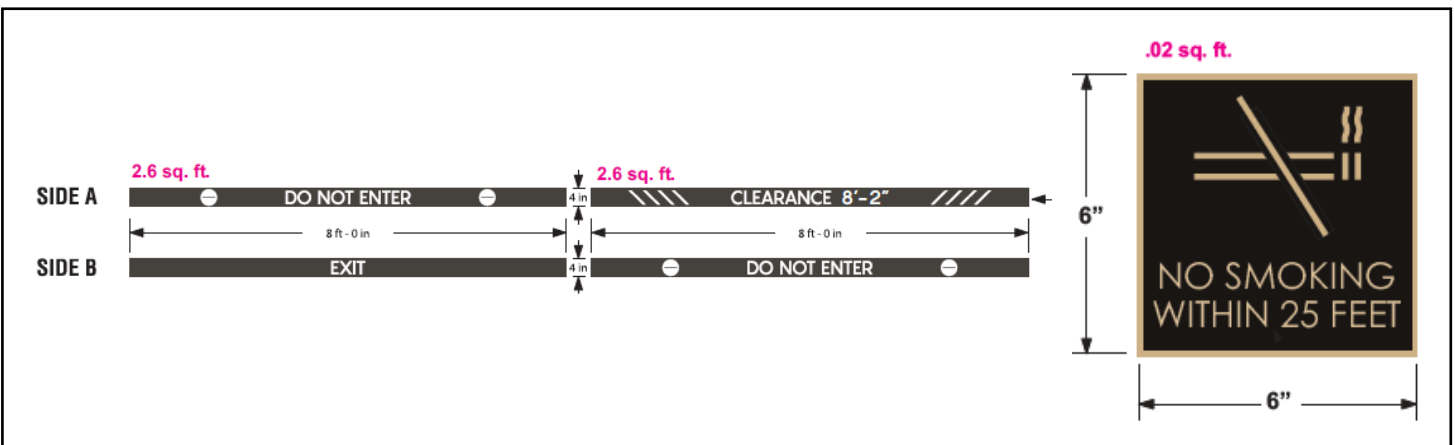



**Projecting Signs (21) – Tenant Name**

**Sign Location:** 3 along W. Atlantic Avenue, 1 along S. Swinton Avenue, 2 along SW 1<sup>st</sup> Street, 2 along SW 1<sup>st</sup> Avenue, and 12 internal to the site.

**Proposed height:** 24”

**Proposed width:** 24”

**Proposed sign Area:** 4 sq. ft.

**Material and Color:** Aluminum with faux finish.

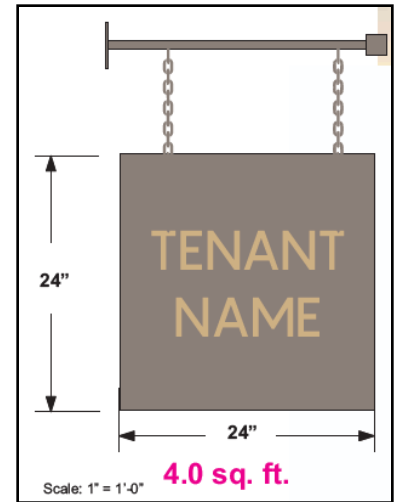

**Nameplate (29) (20 - Tenant Name and 12 – Address)**

**Sign Location:** Tenant – 5 along S. Swinton Avenue (historic structures), 2 along SW 1<sup>st</sup> Street, 4 along SW 1<sup>st</sup> Avenue, 1 at the corner of W. Atlantic Avenue & SW 1<sup>st</sup> Avenue, and 8 internal to the site.  
**Address –** 2 along W. Atlantic Avenue, 1 along S. Swinton Avenue, 4 along SW 1<sup>st</sup> Avenue, 1 at the corner of W. Atlantic Avenue & SW 1<sup>st</sup> Avenue, and 1 internal to the site.

**Proposed height:** Ranges between 6” to 8”

**Proposed width:** Ranges between 1’ to 1’-3/4”

**Proposed sign Area:** 0.66 sq. ft. to 0.88 sq. ft.

**Material and Color:** Address – Aluminum painted “Cast Bronze” & White Vinyl. Tenant - Painted “Cast bronze” with oxidized border and test.

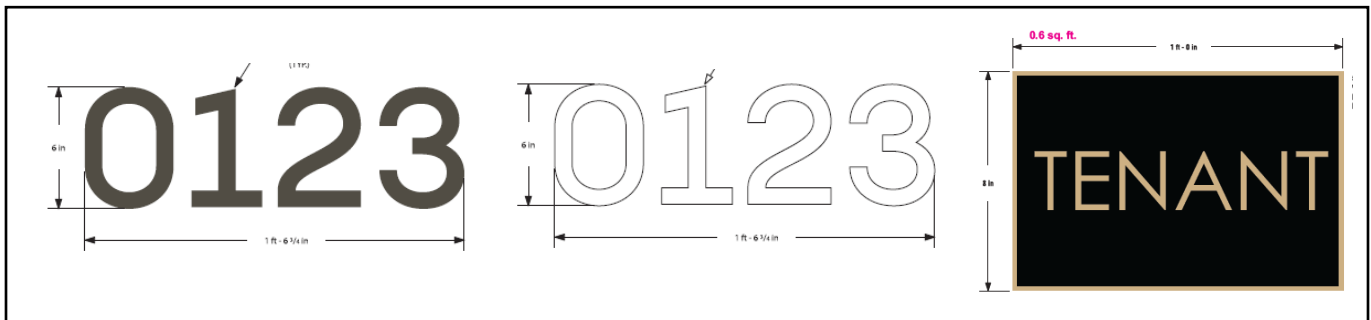

**Directional Signs (9) (6 - Building Direction, and 3 Parking)**

**Sign Location:** Building Direction - 2 at the corner of W Atlantic Avenue & S. Swinton Avenue, 1 along SW 1<sup>st</sup> Avenue, and 3 internal to the site. Parking – 3 along SW 1<sup>st</sup> Avenue.

**Proposed height:** Ranges between 3’ to 6’

**Proposed width:** Ranges between 18” to 3’

**Proposed sign Area:** 2.2 sq. ft. to 18 sq. ft.

**Material and Color:** Building Direction – Coralina or Coquina Stone with “Cast bronze” text – Illuminated light mounted to sign. Parking – Painted “Cast bronze” with gold text, and blue/white parking symbol.

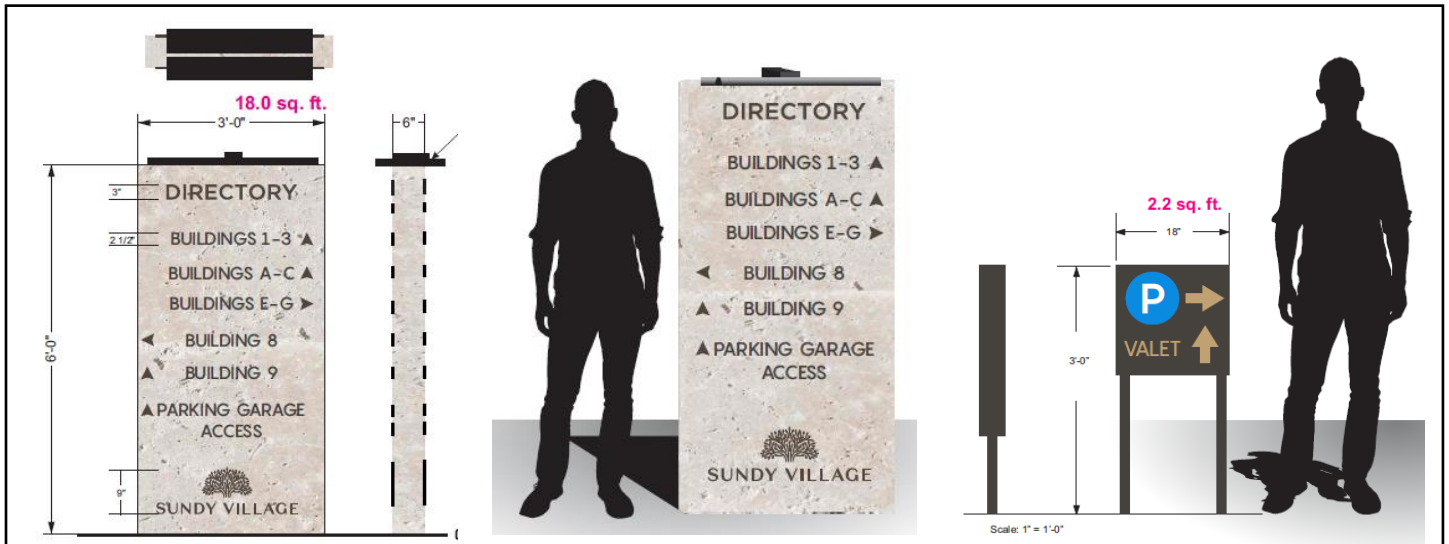

**Free – Standing Monument Signs (11) (10 – Historic Restaurant, and 1 - Site Name)**

**Sign Location:** Historic Restaurant Monument Signs – 5 along S. Swinton Avenue, and 5 internal to the site. Site Name – 1 at the corner of W. Atlantic Avenue & S. Swinton Avenue

**Proposed height:** Ranges between 22” to 5’

**Proposed width:** Ranges between 17” to 71-3/4”

**Proposed sign Area:** 1.4 sq. ft. to 12.5 sq. ft.

**Material and Color:** Historic Restaurant Monument Sign – Coralina or Coquina with aluminum plaque painted “Cast bronze” and illuminated ground lighting. Site Name – Aluminum painted “Cast bronze” and illuminated by the fountain lighting.

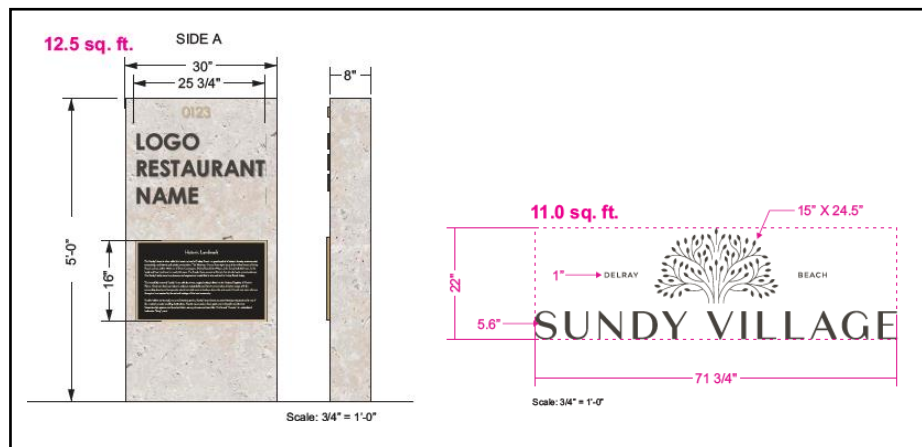

**Free – Standing – Historic Signage (9)**

**Sign Location:** Historic Information - 9 internal to the site.

**Proposed height:** Ranges between 2-4”

**Proposed width:** Ranges between 17”

**Proposed sign Area:** 1.4 sq. ft.

**Material and Color:** Historic Information – Aluminum, painted “Cast bronze” with oxidized border and text.

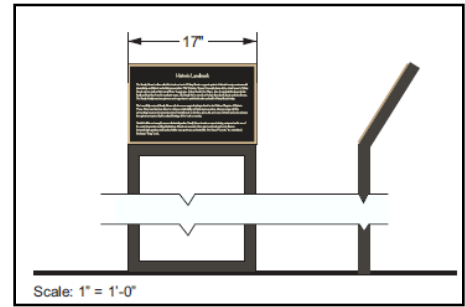

**Directory Signs (2)**

**Sign Location:** Retail Tenant - along SW 1<sup>st</sup> Avenue. Tenant Panels - at the corner of W. Atlantic Avenue & SW 1<sup>st</sup> Avenue

**Proposed height:** Ranges between 36” to 48”

**Proposed width:** 10’

**Proposed sign Area:** 24.2 sq. ft. to 30 sq. ft.

**Material and Color:** Retail Tenant – Aluminum letter painted “Cast bronze” and illuminated by landscape lighting. Tenant Panels – Aluminum cabinet painted dark bonze with “Friskit” painted copy and illuminated by landscape lighting.

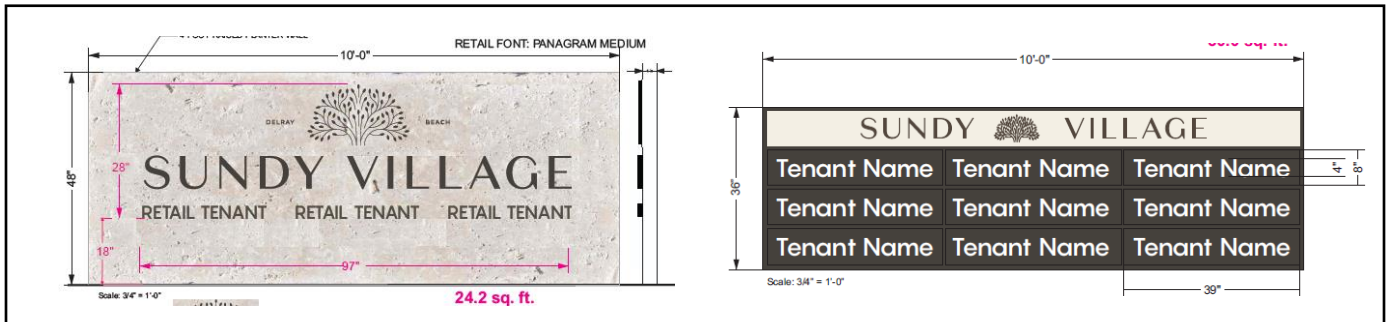

**Block 69**

**Wall sign (1) - Garage**

**Sign Location:** At least one East - Entrance to the parking garage.

**Proposed height:** 54”

**Proposed width:** 25.8”

**Proposed sign Area:** 96.7 sq. ft.

**Material and Color:** Aluminum, Painted “Cast bronze” with reverse backlit channel letters. LED digital display.

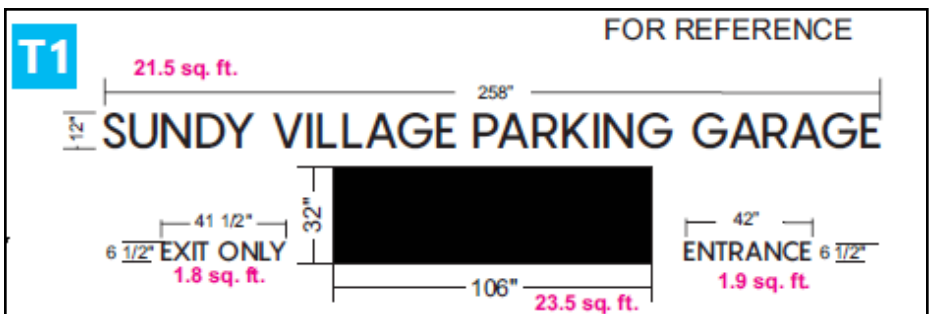

**Projecting Signs – Tenant Name**

**Sign Location:** At least one South along the arcade

**Proposed height:** 24”

**Proposed width:** 24”

**Proposed sign Area:** 4 sq. ft.

**Material and Color:** Aluminum with faux finish.

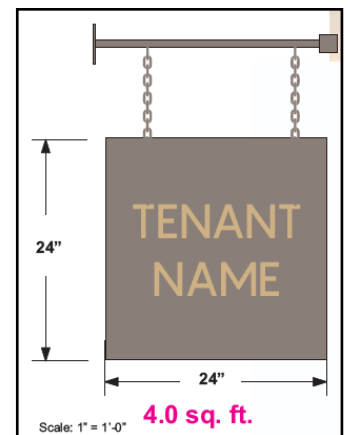

**Block 70**

**Wall signs – Tenant Name**

**Sign Location:** At least one on the fourth floor of the northeast corner of the building and one on the third floor of the east elevation.

**Proposed height:** Ranges between 20” to 47-1/2”

**Proposed width:** Ranges between 89-3/4” to 184-3/4”

**Proposed sign Area:** 25.6 sq. ft. to 29.6 sq. ft.

**Material and Color:** Aluminum, painted “Cast bronze” with reverse channel backlit letters.

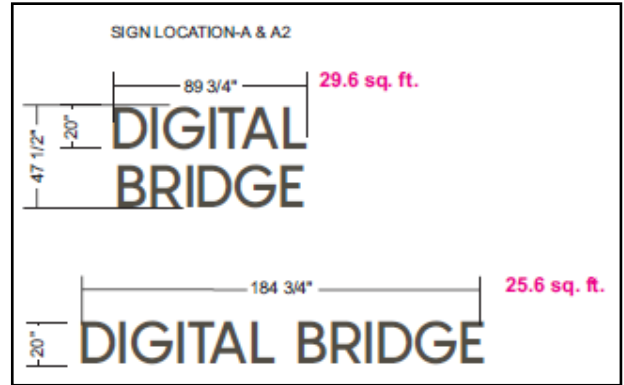

**REVIEW AND ANALYSIS**

Pursuant to Land Development Regulation (LDR) Section 2.4.12(A)(5), prior to approval, a finding must be made that any Certificate of Appropriateness is consistent with Historic Preservation purposes pursuant to Objective HPE 1.4 of the Historic Preservation Element of the Comprehensive Plan; the provisions of Section 4.5.1; the Delray Beach Historic Preservation Design Guidelines; and, the Secretary of the Interior’s Standards for Rehabilitation.

**LDR SECTION 4.5.1 HISTORIC PRESERVATION**

**HISTORIC PRESERVATION: DESIGNATED DISTRICTS, SITES, AND BUILDINGS**

Pursuant to LDR Section 4.5.1(E), Development Standards, all new development or exterior improvements on individually designated historic properties and/or properties located within historic districts shall, comply with the goals, objectives, and policies of the Comprehensive Plan, the Delray Beach Historic Preservation Design Guidelines, the Secretary of the Interior’s Standards for Rehabilitation, and the Development Standards of this Section.

**Pursuant to LDR Section 4.5.1(E)(2) – Major and Minor Development.**

The subject application is considered “Minor Development” as it involves “the construction, reconstruction, or alteration of a building less than 25 percent of the existing floor area, and all appurtenances”.

**Pursuant to LDR Section 4.5.1(E)(3) – Buildings, Structures, Appurtenances and Parking: Buildings, structures, appurtenances and parking shall only be moved, reconstructed, altered, or maintained, in accordance with this chapter, in a manner that will preserve the historical and architectural character of the building, structure, site, or district:**

**Appurtenances: Appurtenances include, but are not limited to, stone walls, fences, light fixtures, steps, paving, sidewalks, signs, and accessory structures.**

This request includes the placement of multiple signs throughout a multi-tenant, multi-block development. The request is made through the master sign program, to allow for the type and numbers of signs to exceed the regulations.

**Pursuant to LDR Section 4.5.1(E)(5) - Standards and Guidelines: a historic site, building, structure, improvement, or appurtenance within a historic district shall only be altered, restored, preserved, repaired, relocated, demolished, or otherwise changed in accordance with the**

Secretary of the Interior's Standards for Rehabilitation, and the Delray Beach Historic Preservation Design Guidelines, as amended from time to time.

The Delray Beach Historic Preservation Design Guidelines lists a series of recommended approaches to signage within historic districts. This includes the following:

- Use materials and sign types that are based on historical precedent. For example, the use of neon tubing was common during the Art Deco period but is inappropriate for buildings of another historical period.
- Place signage so significant architectural detail is not obscured.
- In commercial districts, the valance of an awning is often a visible and unobtrusive location for signage.
- Use indirect lighting when illuminating the sign.
- Avoid cabinet or box signs unless there is historical precedent.
- Ground-mounted signs are appropriate in cases of residential conversions.
- The scale of the signage should relate to the scale and detail of the historic building, and not overwhelm or call attention to the sign.
- The choice of typeface is a recommended way of conveying the period in which the building was constructed. Historic photographs of the period may be consulted to identify some common typestyles.
- The material of the sign need not be identical, but should be compatible with the construction materials of the building.
- For signs that are used in residential conversions, the application materials, of the original and sometimes details, is a recommended approach to sign design. For example, for a masonry building, a masonry monument sign may be an appropriate choice. If the building possesses a parapet detail, the signage may reflect that detail, tying the two together.

Generally, the proposed materials are considered to be appropriate for signage within a historic district (stone, coquina, stucco, and vinyl). A majority of the proposed signs utilize indirect lighting, aside from the wall mounted signage which are proposed to be backlit.

There are concerns with the material, type, and size of proposed signs in association with the historic structures along S. Swinton Avenue. The proposal includes ten 5' tall stone, ground mounted, monument signs to be located in the front and rear of the historic structures. The Design Guidelines state that **sign material should be compatible with the construction materials of the buildings** and the buildings are either wood frame or stucco exteriors. Additionally, these structures were originally constructed as residences and later converted for commercial use. The recommended approach for the design of proposed signage for structures that were converted from residential use is to **incorporate materials from the structure into the design of the sign (for example a wood sign would be an appropriate choice for a wood frame structure)**. Further, the use of compatible signage would aid in communicating the historic nature of the structures where the site is largely comprised of new construction.

While the stone monument signs might be considered consistent with the overall sign proposal across the Sundy Village site, there are concerns that these 10 signs may not meet the design and historic requirements of the Design Guidelines. It is noted that city staff provided this guidance to the applicant

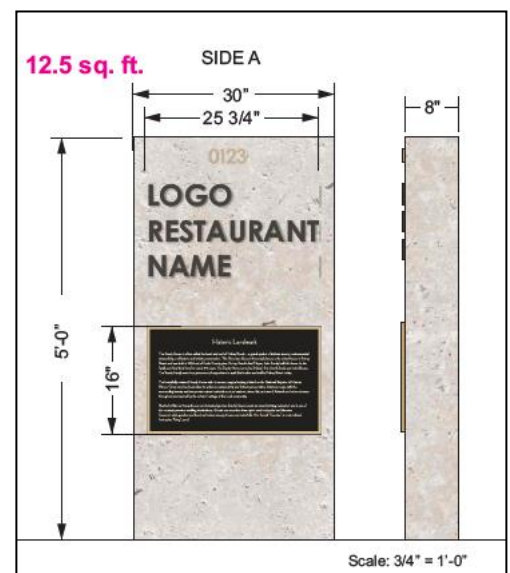

prior to the board meeting and encouraged the use of signage that would be historically compatible with the existing historic structures.

Another concern are the proposed tenant signs at the northwest and northeast corners of Buildings 1, 2, & 3, facing W. Atlantic Avenue. The tenant signage eliminates porch railings, an architectural element integral to the design of the structure. Additionally, the signage does not appear to be compatible with the historic district (see image to right). An alternative for such signage would be to place tenant signage within the civic open space area rather than eliminating the porch railing architectural details.



## **SECRETARY OF THE INTERIOR'S STANDARDS**

### **Standard 1**

**A property shall be used for its historic purpose or be placed in a new use that requires minimal change to the defining characteristics of the building and its site and environment.**

### **Standard 2**

**The historic character of a property shall be retained and preserved. The removal of historic materials or alteration of features and spaces that characterize a property shall be avoided.**

### **Standard 3**

**Each property shall be recognized as a physical record of its time, place, and use. Changes that create a false sense of historical development, such as adding conjectural features or architectural elements from other buildings, shall not be undertaken.**

### **Standard 4**

**Most properties change over time; those changes that have acquired historic significance in their own right shall be retained and preserved.**

### **Standard 5**

**Distinctive features, finishes, and construction techniques or examples of craftsmanship that characterize a historic property shall be preserved.**

### **Standard 6**

**Deteriorated historic features shall be repaired rather than replaced. Where the severity of deterioration requires replacement of a distinctive feature, the new feature shall match the old in design, color, texture, and other visual qualities and, where possible, materials. Replacement of missing features shall be substantiated by documentary, physical, or pictorial evidence.**

### **Standard 7**

**Chemical or physical treatments, such as sandblasting, that cause damage to historic materials shall not be used. The surface cleaning of structures, if appropriate, shall be undertaken using the gentlest means possible.**

**Standard 8**

**Significant archeological resources affected by a project shall be protected and preserved. If such resources must be disturbed, mitigation measures shall be undertaken.**

**Standard 9**

**New additions, exterior alterations, or related new construction shall not destroy historic materials that characterize the property. The new work shall be differentiated from the old and shall be compatible with the massing, size, scale, and architectural features to protect the historic integrity of the property and its environment.**

**Standard 10**

**New additions and adjacent or related new construction shall be undertaken in such a manner that if removed in the future, the essential form and integrity of the historic property and its environment would be unimpaired.**

Standard 1, 2, 3, 5, 9 and 10 are applicable. The proposal involves the installation of signage across the entirety of the 6.902 acre Sundy Village site. Within the site several historic structures exist along with several newly constructed buildings. The proposed Master Sign Program incorporates a cohesive design of signage throughout the site. There are concerns with the design of signage adjacent to the existing historic structures along S. Swinton Avenue. The proposed ground mounted, stone signs have been designed to be cohesive with the signage across the entirety of the Sundy Village site and do not appear to be compatible with the historic structures. Most of the structures are wood frame with wood siding, with the exception of one structure, a stuccoed exterior Bungalow style structure.

With regards to **Standard 1**, the existing historic structures were once residences and have been converted to commercial use. The introduction of Modern style stone signage does not appear to be compatible with the historic appearance of the former residences and could be seen as changing the characteristics of the site and its historic environment.

Regarding **Standard 2**, the proposed signage adjacent to the historic structures along S. Swinton Avenue could represent an alteration of the spaces that characterize the property as a historic site and as former residential uses. Consideration should be given to redesign signage adjacent to the historic structures to be more compatible with the style of the structures and the overall Old School Square Historic District.

Regarding **Standard 3**, the subject site contains 6.902 acres across four blocks of land within and near the downtown. Historically, residential uses existed within the structures along S. Swinton Avenue. The intent of the OSSHAD zoning district, a mixed-use district, is to provide for mixed uses of residential, office, and commercial activities, with an emphasis on the arts, that will encourage the restoration or preservation of historic structures and, yet, maintain and enhance the historic and pedestrian scale of the area; stimulate greater awareness and pride in the City's architectural heritage, and create an atmosphere and feeling of "Old Delray Beach"; improve the environmental quality and overall livability of this Historic District and stabilize and improve property value therein, and; and to allow uses which promote preservation and adaptive reuse of all structures within the District. Overall, the Sundy Village project meets this intent, but it is important to retain and support the original sense of historical development within this historic district. The proposed 5' tall, ground mounted, stone signs could be seen as creating a false sense of historical development through adding conjectural features and architectural elements from other building styles to the modest historic wood frame structures. It is important to ensure the historic scale, style, architecture, and feeling of "Old Delray Beach" of the historic structures is maintained while also allowing their adaptive reuse as commercial structures.

Finally, regarding **Standards 5 & 9**, the proposed ground mounted, stone signs could be seen as the introduction of exterior alterations to the site that are not in keeping with the character of the property. While new work shall be differentiated from old it must also be compatible with the massing, size, scale, and architectural features of the site in order to protect the historic integrity of the property and its environment (the historic district). Consideration should be given to incorporate signage around the historic homes that is more appropriate from a material, style, and scale perspective. Additionally, the proposed tenant signage at the northwest and northeast corners of newly constructed Buildings 1, 2, & 3 should be placed elsewhere on the site in order to protect the architectural integrity of the railings, which are a design element integral to the design of the building.

**Pursuant to LDR Section 4.5.1(E)(7) - Visual Compatibility Standards: new construction and all improvements to both contributing and noncontributing buildings, structures and appurtenances thereto within a designated historic district or on an individually designated property shall be visually compatible. In addition to the Zoning District Regulations, the Historic Preservation Board shall apply the visual compatibility standards provided for in this Section with regard to height, width, mass, scale, façade, openings, rhythm, material, color, texture, roof shape, direction, and other criteria set forth elsewhere in Section 4.5.1. Visual compatibility for minor and major development as referenced in Section 4.5.1(E)(2) shall be determined by utilizing criteria contained in (a)-(m). Visual compatibility for all development on individually designated properties outside the district shall be determined by comparison to other structures within the site.**

- g. Relationship of materials, texture, and color. The relationship of materials, texture, and color of the facade of a building and/or hardscaping shall be visually compatible with the predominant materials used in the historic buildings and structures within the subject historic district.**
- i. Architectural Style, all major and minor development shall consist of only one architectural style per structure or property and not introduce elements definitive of another style.**

The proposed signage adjacent to the historic structures includes the use of stone monument signs where the historic structures are wood frame with wood siding or stucco exteriors. The proposed signs represent the introduction of a different architectural style and material, which may not be considered appropriate for the Frame Vernacular and Bungalow architectural styles of the historic structures. Compliance with this standard can be made by utilizing signage styles with appropriate materials to be visually compatible with the style of the historic structures.

The board will need to make a determination that the proposal is in compliance with the requirements of LDR Section 4.5.1, the Secretary of the Interior's Standards and Guidelines, and the Delray Beach Historic Preservation Design Guidelines.

#### **LDR SECTION 4.6.7 - SIGNS**

**Pursuant to LDR Section 4.6.7(F)(2)(b), Signs requiring permits: Master sign and blanket sign programs. "A Master Sign Program is to be used when the development of a project is of such a scale or character that the normal application of the design and/or aesthetic standards of Subsections (D) and (E), respectively, will not result in an effective sign program and signing more permissive than said standards is necessary. Approval of a Master Sign Program may include the automatic granting of waivers and/or adjustments to the provisions of Subsections (D) and (E) provided that the intent of the sign code is maintained, and the character of the**



**community and neighborhood is not diminished. A Master Sign Program shall be approved by the Site Plan Review and Appearance Board or if the project is in a historic district or historically designated site, by the Historic Preservation Board. After approval of a Master Sign Program, individual signs consistent therewith shall be administratively approved.”**

**LDR Section 4.6.7(F)(2)(c), Signs requiring permits: Master sign and blanket sign programs. “Nothing contained herein shall prevent diversity and creativity of individual signs in the Master Sign Program.”**

**LDR Section 4.6.7(D)(2), Aesthetic qualifications: Basis, “the aesthetic quality of a building, or of an entire neighborhood, is materially affected by achieving visual harmony of the sign on or about a structure as it relates to the architecture or the building or the adjacent surroundings. In addition to the limitations on signs imposed in Subsections (E) and (K), the following aesthetic considerations must be met.**

- a) Garishness: The overall effect of the lettering, configuration or color of a sign shall not be garish. "Garish" signs are those that are too bright or gaudy, showy, glaring, and/or cheaply brilliant or involving excessive ornamentation. Garish signs are not in harmony with and are not compatible with the building or adjacent surroundings.**
- b) Scale, design, and location:**
  - 1. Signs shall be appropriate in size, scale, and design for the neighborhood or streetscape where it is to be located.**
  - 2. Signs placed on structures shall be proportionate in size and scale to the building facade, designed consistently with the building architecture, and positioned harmoniously with building features; architectural features shall not be provided solely for the purpose of accommodating signage, but shall relate to building location, function, and use.**
- c) Quality: All signs shall have a professional appearance that enhances the visual aesthetics of the area.”**

The Master Sign Program as articulated in LDR Section 4.6.7(F)(2)(b), is to be utilized when the development of a project is of such scale or character that the normal application of the design and/or aesthetic standards of Subsections (D) and (E), respectively, will not result in an effective sign program and can be more permissive than said standards is necessary. The master sign program thoroughly facilitates the automatic granting of waivers and adjustments to Subsections (D) and (E), thereby safeguarding the intrinsic principles of the sign code and the character of the community.

The table below provides details of the allowed regulations and proposed signs configuration. As this is a multi-tenant site, the proposed signage exceeds the code allowances relating to size per face, per lot, number of signs per parcel & development. The proposal involves a cohesive sign proposal across the 6.902 acre historic site. Signs are intended to be provided per tenant, which includes a similar number of signs per space. The signs are proposed to identity each tenant space, so they are visible from a distance as well as on the site. There are directional, and directory signage proposed to be placed in and around the site to direct pedestrians throughout the site.

There are concerns with the proposed materials and design of signs associated with the historic structures as well as tenant signs on the front of Buildings 1, 2, & 3 (facing W. Atlantic Avenue). There is also concern, regarding the location of a wayfinding sign (W5), which is situated outside of the property lines at the corner of SW 1<sup>st</sup> Avenue and W. Atlantic Avenue (northwest corner of the site). This sign is between the sidewalk and the property line, and while it is not within any site visibility triangles, signs specific to the site are to remain within the property.

**Pursuant to LDR Section 4.6.7(E)(3)(c)(2)(b), Projecting signs.**

1. Projecting signs may be located within the setback, including special setback areas pursuant to Section 4.3.4(H)(6); or
2. Projecting signs within the CBD or OSSHAD with CBD Overlay zoning districts may be located partially or entirely in the public right-of-way provided that the building or arcade was legally constructed with smaller setbacks or without setbacks, subject to the following:
  - a. Projecting signs that extend into the right-of-way more than two feet from the face of the building or contain more than five square feet are subject to approval by either the Site Plan Review and Appearance Board or Historic Preservation Board.
  - b. Projecting signs may extend from the face of the building located under an arcade. Projecting signs shall not extend from the exterior face of an arcade.

Since a portion of the site is within the OSSHAD with CBD Overlay, Section 2(b) above is applicable. There are a series of projecting signs placed on the face of the arcade of Buildings 1, 2, & 3 and may not extend from the exterior face of an arcade. An added site plan technical item is that the proposed projecting signs be changed to be compliant with the LDRs.

**Block 61:**

Type of Sign	Zoning District	Quantity		Area (max.)	
		Allowed	Proposed	Allowed	Proposed
Free Standing	OSSHAD	Up to two per lot, parcel or development	10 – W6	30 Square feet per face	W6 – 12.5 sq. ft.
	OSSHAD w. CBD Overlay	One per frontage	1-W7	One sign equal to half the length of the property's frontage in square feet, not to exceed 160 square. Each additional sign is limited to 50 square feet.	W7 – 11.0 sq. ft.
Projecting	OSSHAD	Up to two per lot, parcel or development	13 – T3	30 square feet per face	T3 – 4 sq. ft.
	OSSHAD w. CBD Overlay	One per business	8 – T3	30 square feet per face 3 feet from face of wall	T3 – 4 sq. ft.
Wall	OSSHAD	Up to two per lot, parcel or development	10 – T1 1 – G1	30 square feet	T1 – 4.9-9.2 sq. ft. G1 – 38.1 sq. ft.
	OSSHAD w. CBD Overlay	One per business One per building	9 – T1	15% of building face, not to exceed 160 square feet 9 square feet	T1 – 12.6-15.9 sq. ft.
Directory		One per building	1 – W1 1 - W2	24 square feet	W1 – 24.2 sq. ft. W2 – 30 sq. ft.
Directional	Exempt	N/A	6 – W3 3 – W5	4 square feet	W3 – 18 sq. ft. W5 – 2.2 sq. ft.
Historic		N/A	9 – H2	3 square feet	1.4 sq. f.t
Nameplate	Exempt	One nameplate per building	20 – T2 9 – B1 3 – B2	3 square feet	T2 – 0.6 sq. ft. B1 – 0.75 sq. ft. B2 – 0.75 sq. ft.
Instructional	Exempt	N/A	1 – G2 11 – T2.1	3 square feet	G2 – 2.6 sq. ft. T2.1 - .02 sq. ft.

**Block 61 Cont'd:**

Type of Sign	Zoning District	Location		Height		Illumination Type (Direct/indirect)
		Allowed	Proposed	Allowed	Proposed	
Free Standing	OSSHAD	May be in front yard setback	All within property except	8 feet	W6 – 5ft	W6 - Indirect
	OSSHAD w. CBD Overlay	None	Corner of W. Atlantic Avenue & S. Swinton Avenue	14 feet	W7 – 5ft	W7 - Indirect
Projecting	OSSHAD	From building or under canopy	From building	-	-	T3 Indirect
	OSSHAD w. CBD Overlay	From building or under canopy	From building	-	-	T3 Indirect

**HISTORIC PRESERVATION BOARD | September 4, 2024  
Sundy Village – Master Sign Program**

<b>Wall</b>	OSSHAD	On building face	On building face	-	-	T1 – Direct G1 - Direct
	OSSHAD w. CBD Overlay	Facing each dedicated street frontage On rear of building not facing street	Facing each dedicated street frontage	-	-	T1 – Direct
<b>Directory</b>	OSSHAD w. CBD Overlay	On building face	Freestanding	-	W1 – 4' W2 – 3'	W1 – Indirect W2 - Indirect
<b>Directional</b>	OSSHAD & OSSHAD w. CBD Overlay	Exempt	Within Property – 1 W3 outside of property line along SW 1 <sup>st</sup> Avenue	5 feet	W3 – 6ft W5 – 3ft	W3 – Indirect W5 - Indirect
<b>Historic</b>	OSSHAD	-	Within property	6 feet	H2 – approx. 3 ft	H2 - Indirect
<b>Nameplate</b>	OSSHAD & OSSHAD w. CBD Overlay	Exempt	On building face	-	-	-
<b>Instructional</b>	OSSHAD & OSSHAD w. CBD Overlay	Exempt	Within Property	5 feet	T2.1 – 6" G2 – 4"	T2.1 – Indirect G2 - Indirect

**Block 69:**

Type of Sign	Zoning District	Quantity		Area (max.)	
		Allowed	Proposed	Allowed	Proposed
<b>Projecting</b>	OSSHAD w. CBD Overlay	One per business	2 – T3	30 square feet per face 3 feet from face of wall	T3 – 4 sq. ft.
<b>Wall</b>	OSSHAD w. CBD Overlay	One per business One per building	One per building	15% of building face, not to exceed 160 square feet 9 square feet	Overall, 96.7 sq. ft. (21.5sq.ft. T1, 1.8-9sq.ft. directional, 23.5sq.ft. informational.

**Block 69 Cont'd:**

Type of Sign	Zoning District	Location		Height		Illumination Type (Direct/Indirect)
		Allowed	Proposed	Allowed	Proposed	
<b>Projecting</b>	OSSHAD w. CBD Overlay	From building or under canopy	From building and under canopy	-	-	T3 Indirect
<b>Wall</b>	OSSHAD w. CBD Overlay	facing each dedicated street frontage on rear of building not facing street	Facing dedicated street	-	-	Direct & Indirect

**Block 70:**

Type of Sign	Zoning District	Quantity		Area (max.)	
		Allowed	Proposed	Allowed	Proposed
<b>Wall</b>	OSSHAD w. CBD Overlay	One per business One per building	One per building or alternate of 2 per building.	15% of building face, not to exceed 160 square feet 9 square feet	Single requested size, 29.6 sq. ft. Alternate (2), 25.6 sq. ft. each

**Block 70 Cont'd:**

Type of Sign	Zoning District	Location		Height		Illumination Type (Direct/Indirect)
		Allowed	Proposed	Allowed	Proposed	
<b>Wall</b>	OSSHAD w. CBD Overlay	facing each dedicated street frontage on rear of building not facing street	Facing dedicated street	-	-	Direct

Should the request be approved by the board, it is noted that any future modifications or requests for alterations and/or additional signage, including considerations of size, color, and placement, is considered an amendment to the approved Master Sign Program and may require board approval.

Master Sign Programs allow for such additions, provided they align with the surrounding environment in terms of size, scale, design, and appropriateness of location.

**COMPREHENSIVE PLAN**

**Pursuant to the Historic Preservation Element (HPE), Objective 1.4, Historic Preservation Planning: Implement appropriate and compatible design and planning strategies for historic sites and properties within historic districts.**

The objective shall be met through continued adherence to the City’s Historic Preservation Ordinance and, where applicable, to architectural design guidelines through the following policies:

**HPE Policy 1.4.1 - Continue to require that the Historic Preservation Board make findings that any land use or development application for a historic structure, site or within a historic district, is consistent with the provisions of the Secretary of the Interior’s Standards for Rehabilitation, the Land Development Regulations, and Delray Beach Historic Preservation Design Guidelines.**

The proposal is for a master sign program for the multi-block Sundy Village project. The board will need to make a determination that the request can be found to be consistent with the provisions of LDR Section 4.5.1 relating to historic sites and districts as well as the Secretary of the Interior’s Standards and the Delray Beach Historic Preservation Design Guidelines.

**SITE PLAN TECHNICAL ITEMS**

1. That proposed projecting signs on the face of the building arcades within the OSSHAD with CBD overlay zoned portion of the project be changed to be compliant with the LDRs.

**ALTERNATIVE ACTIONS**

- A. Move to continue with direction.
- B. Approve Certificate of Appropriateness and Master Sign Program (2024-162), for the property located at **Sundy Village, Old School Square Historic District**, by finding that the request and approval thereof is consistent with the Comprehensive Plan and meets the criteria set forth in the Land Development Regulations.
- C. Approve Certificate of Appropriateness and Master Sign Program (2024-162), for the property located at **Sundy Village, Old School Square Historic District**, by finding that the request and approval thereof is consistent with the Comprehensive Plan and meets the criteria set forth in the Land Development Regulations, subject to the following conditions:
- D. Deny Certificate of Appropriateness and Master Sign Program (2024-162), for the property located at **Sundy Village, Old School Square Historic District**, by finding that the request is inconsistent with the Comprehensive Plan and does not meet the criteria set forth in the Land Development Regulations.

**PUBLIC AND COURTESY NOTICES**

<input checked="" type="checkbox"/> Courtesy Notices are not applicable to this request	<input checked="" type="checkbox"/> Public Notices are not required for this request. <input checked="" type="checkbox"/> Agenda was posted on (08/28/24), 5 working days prior to the meeting.
---	--



# SUNDY VILLAGE

---

MASTER SIGN PLAN

# SUNDY VILLAGE - LOCATION PLAN

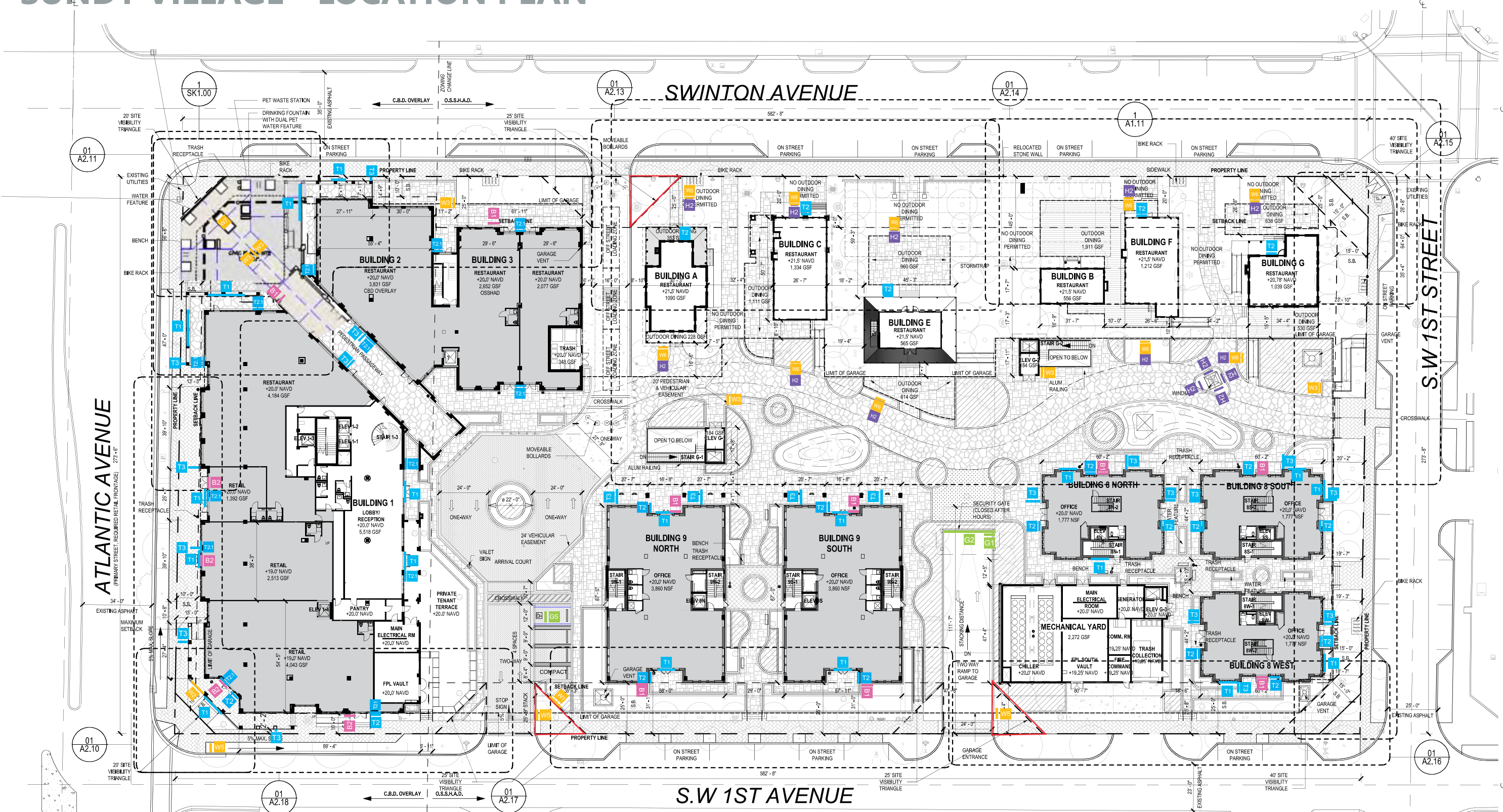

- HISTORIC
- WAYFINDING
- TENANT
- PARKING
- REGULATORY



# SUNDY VILLAGE - Graphic Standards

## STANDARD FINISHES



MP07458 CAST BRONZE  
MATTHEWS PAINT



Tenant Letters/Wayfinding



ADDRESS NUMBERS  
PAINTED MP07458 CAST BRONZE



ADA Sign  
Background



ADA Copy



Material Reference  
To be faux finish

### GENERAL NOTE:

**ALL SIGNAGE NOT TO EXCEED STANDARD  
CODE SQUARE FOOTAGE REQUIREMENTS**

## STANDARD LETTER FONTS

### CENTURY GOTHIC

ABCDEFGHIJKLMNOPQRSTUVWXYZ  
QRSTUVWXYZ1234567890

### PANAGRAM MEDIUM

ABCDEFGHIJKLMNPO  
QRSTUVWXYZ0123456789

### MONUMENT SIGN FACES CORALINA OR COQUINA STONE



### EXAMPLE OF SIGNS FOR CAST PLAQUES

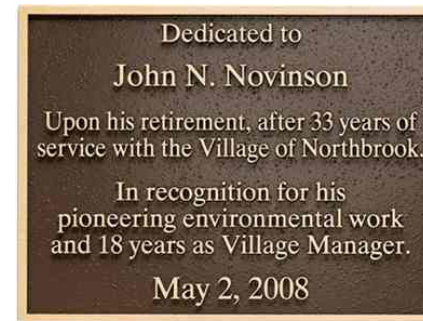

### Vinyl Copy



### DIRECTORY SIGN FACES SMOOTH STUCCO FINISH TO MATCH SW7102 FLOWER WHITE



# G1 - Parking Garage



FONT: PANAGRAM MEDIUM

2" DEEP REVERSE CHANNEL BACKLIT LETTERS.  
PAINTED BRONZE WITH WHITE LED'S.

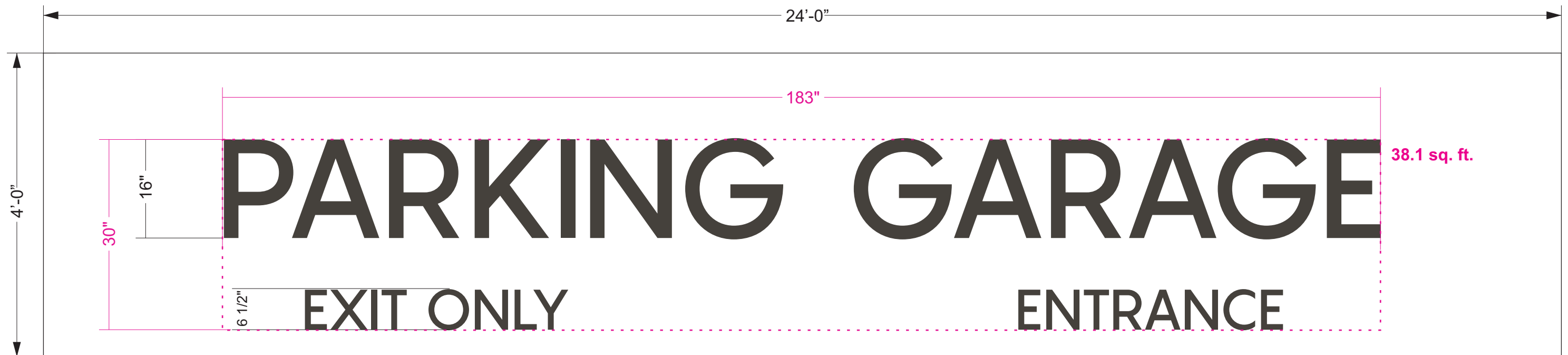

Scale: 3/4" = 1'-0"



MP07458 CAST BRONZE  
MATTHEWS PAINT





# G2 - Garage Clearance



MP07458 CAST BRONZE  
MATTHEWS PAINT

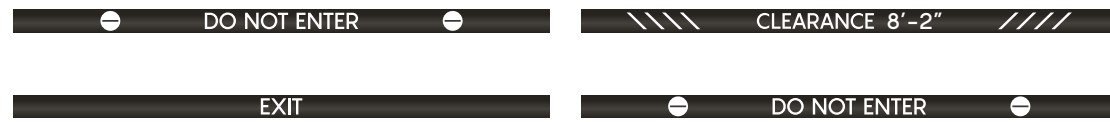
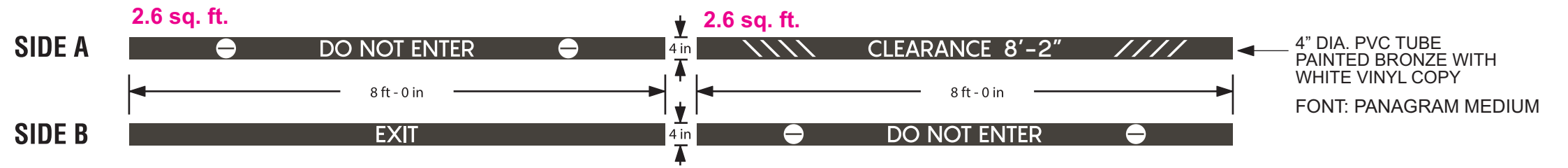

# BUILDING 1 - NORTHWEST SECTION



## NORTH STREETScape ELEVATION @ ATLANTIC AVE

SCALE: NOT TO SCALE



# BUILDING 1 - WEST SECTION



WEST STREETSCAPE BUILDING ELEVATION @ SW 1ST AVE.  
SCALE: NOT TO SCALE

# T1 - Tenant ID

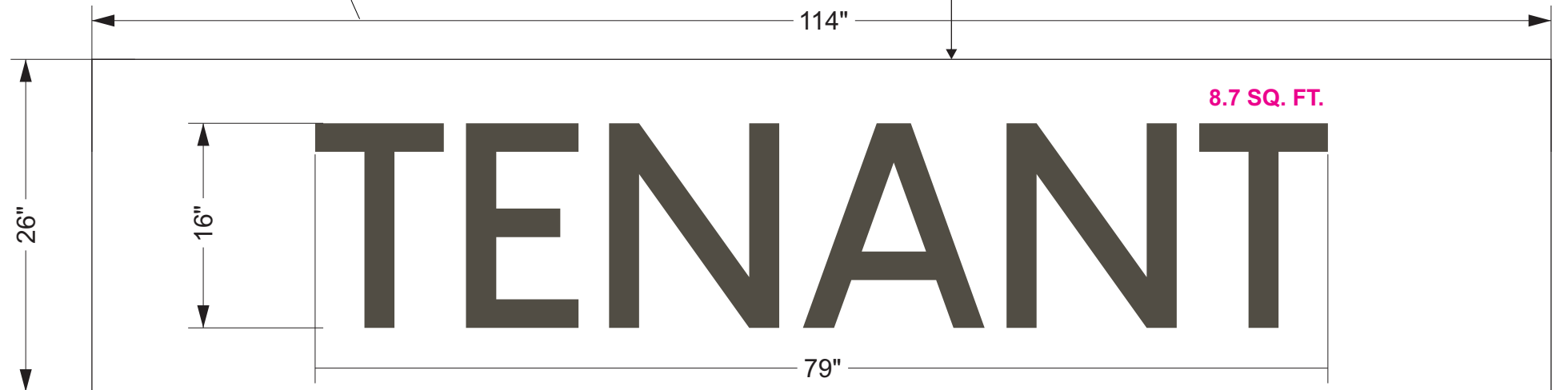
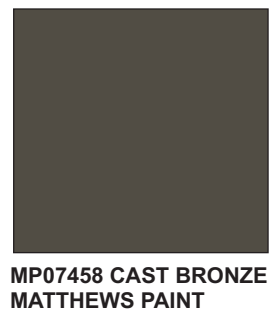
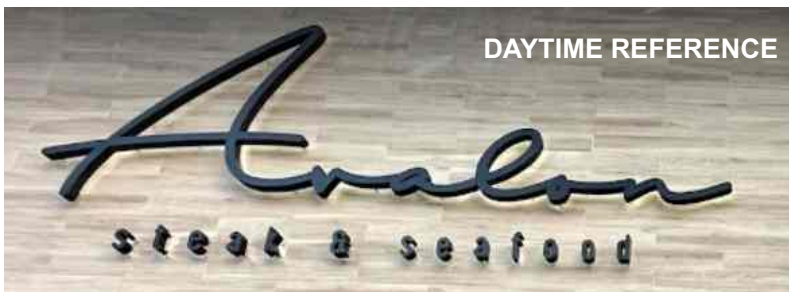
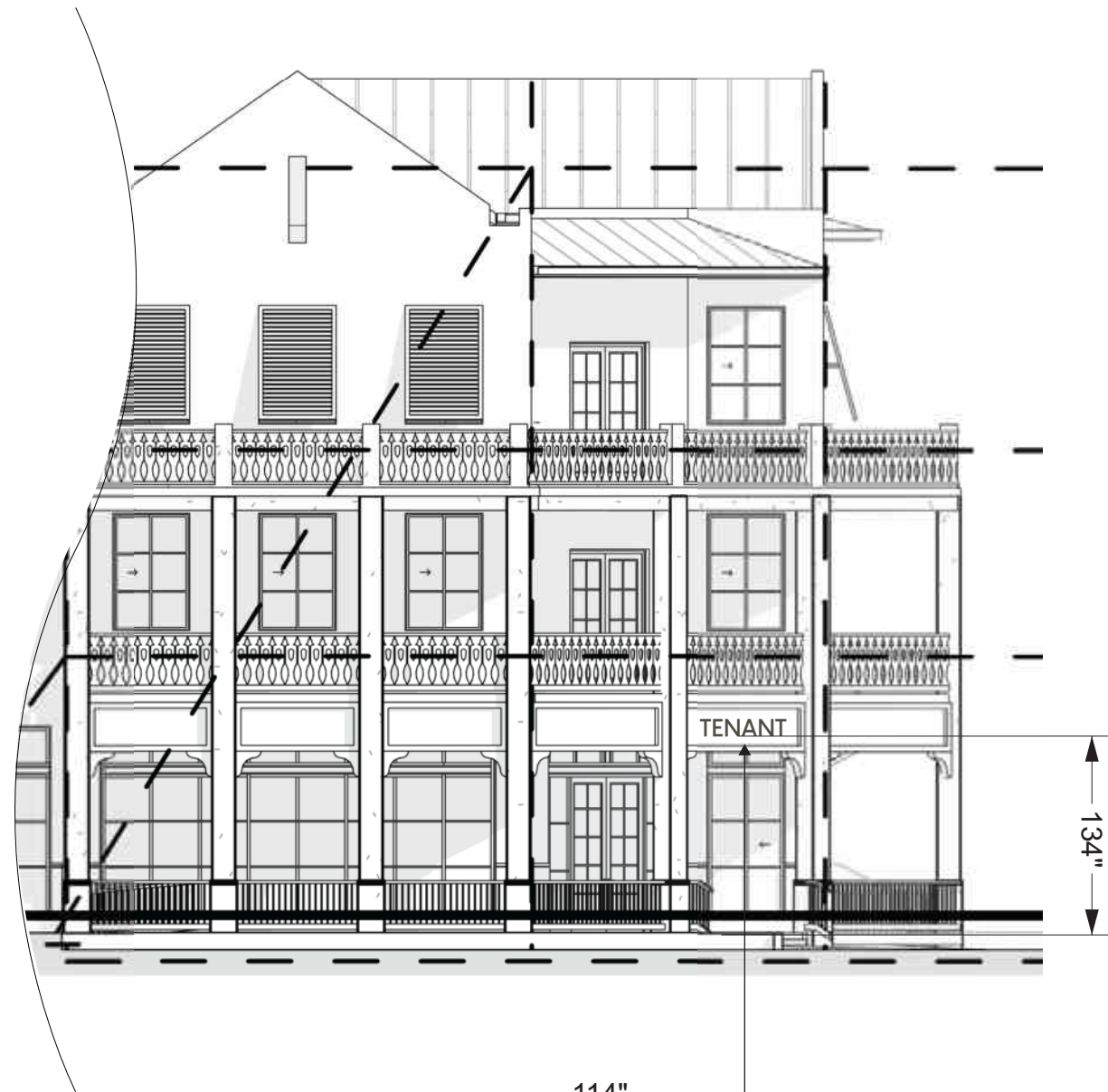

2" DEEP REVERSE CHANNEL BACKLIT LETTERS,  
PAINTED BRONZE WITH WHITE LED'S

Scale: 1" = 1'-0"

FONT: PANAGRAM MEDIUM  
Registered Trademark Fonts/logo allowed with landlord approval

# BUILDING 1-2



## NORTH STREETSCAPE ELEVATION @ ATLANTIC AVE

SCALE: NOT TO SCALE

# BUILDING 1-2-3



## EAST STREETSCAPE ELEVATION @ SWINTON AVE

SCALE: NOT TO SCALE

**T1** - Tenant ID - Retail Tenants-Double Knot



MP07458 CAST BRONZE  
MATTHEWS PAINT

2" DEEP REVERSE CHANNEL BACKLIT LETTERS, PAINTED BRONZE WITH WHITE LED'S

FONT: PANAGRAM MEDIUM  
Registered Trademark Fonts/logo allowed with landlord approval

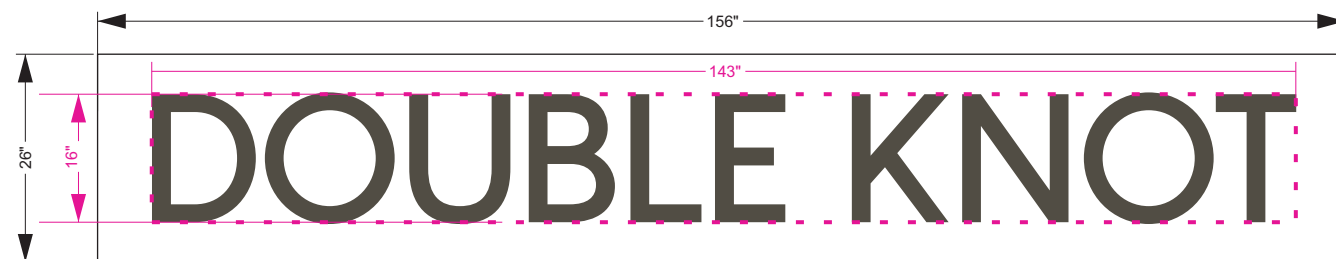

Scale: 1/2" = 1'-0"

15.9 sq. ft.

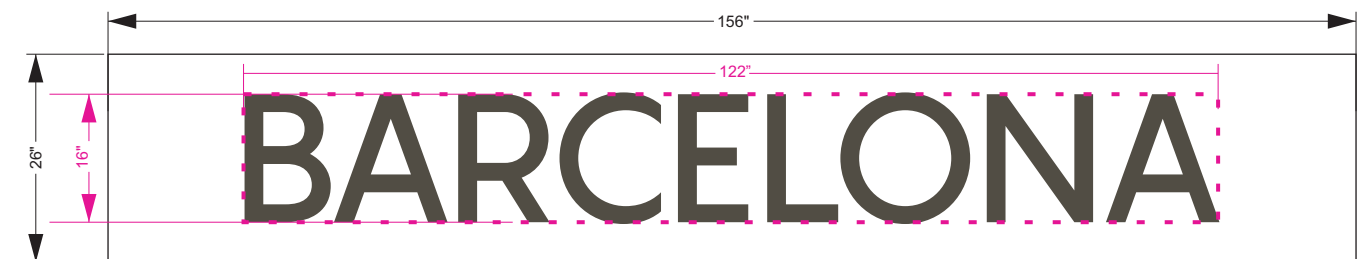

Scale: 1/2" = 1'-0"

13.5 sq. ft.

# BUILDING 1-2



## NORTH STREETSCAPE ELEVATION @ ATLANTIC AVE

SCALE: NOT TO SCALE



**T1** - Tenant ID



PROPOSED NORTH STREETSCAPE ELEVATION @ ATLANTIC AVE  
Scale: 1/8" = 1'-0"



2" DEEP REVERSE BACKLIT CHANNEL LETTERS  
PAINTED BRONZE WITH WHITE LED'S.



# T1 - Tenant ID Building 9

Building 9 North

Building 9 South



PROPOSED WEST STREETSCAPE BUILDING ELEVATION @ SW 1ST AVE.

SCALE: 1" = 20'-0"

9.2 sq. ft.

110"

12" **TENANT NAME**

SCALE: 3/4" = 1'-0"

2" DEEP REVERSE CHANNEL BACKLIT LETTERS,  
PAINTED BRONZE  
WITH WHITE LED'S

FONT: PANAGRAM MEDIUM  
Registered Trademark Fonts/logo allowed  
with landlord approval



MP07458 CAST BRONZE  
MATTHEWS PAINT



**T1** - Tenant ID Building 8

Building 8 West

Building 8 South



PROPOSED SOUTH STREETSCAPE BUILDING ELEVATION @ SW 1ST ST.

SCALE: 1/16" = 1'-0"



MP07458 CAST BRONZE MATTHEWS PAINT

110" width, 12" height  
**TENANT NAME**

9.2 sq. ft.

SCALE: 3/4" = 1'-0"

110" width, 12" height  
**PEBB CAPITAL**

9.2 sq. ft.

2" DEEP REVERSE CHANNEL BACKLIT LETTERS,  
 PAINTED BRONZE  
 WITH WHITE LED'S

FONT: PANAGRAM MEDIUM  
 Registered Trademark Fonts/logo allowed  
 with landlord approval

Building 8 North

Building 8 West

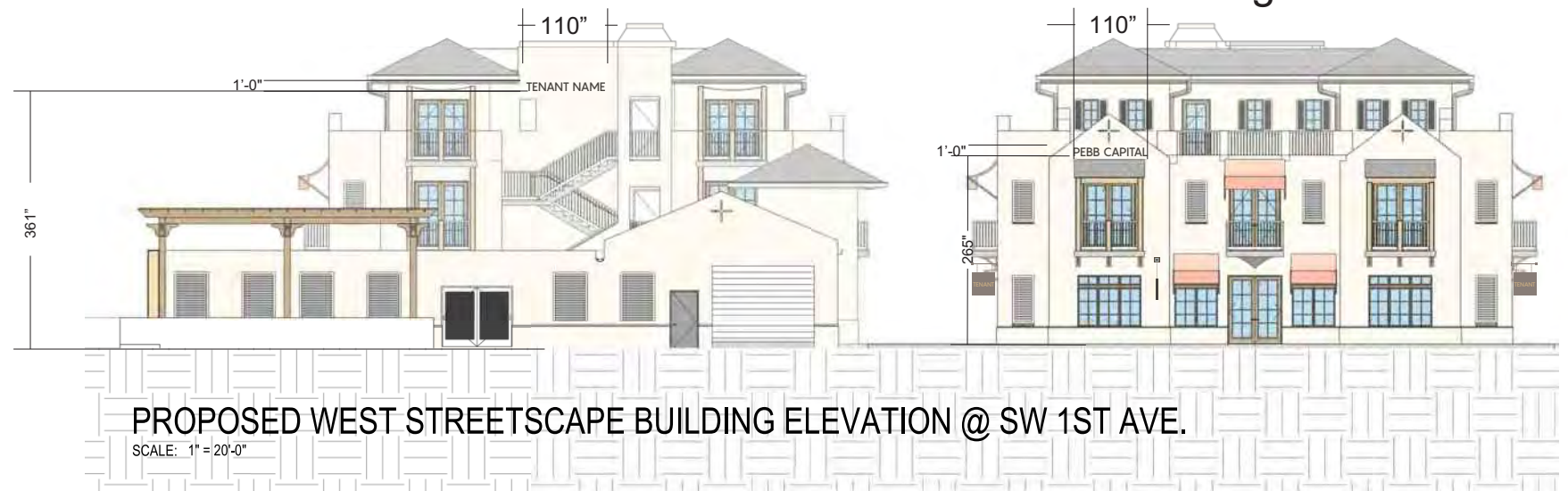

PROPOSED WEST STREETSCAPE BUILDING ELEVATION @ SW 1ST AVE.

SCALE: 1" = 20'-0"

**T1** - Tenant ID Building 8



# T1 - Tenant ID Buildings 8 & 9-Courtyard



BLOCK 61 - COURTYARD WEST ELEVATION @ SW 1ST AVE. - OVERALL  
SCALE: 1" = 20'-0"



MP07458 CAST BRONZE  
MATTHEWS PAINT



SCALE: 3/4" = 1'-0"

2" DEEP REVERSE CHANNEL BACKLIT LETTERS,  
PAINTED BRONZE  
WITH WHITE LED'S

9 SQ FT MAX ALLOWED IN COURTYARD

FONT: PANAGRAM MEDIUM  
Registered Trademark Fonts/logo allowed  
with landlord approval

# T3 - Tenant Blade - Retail Tenants

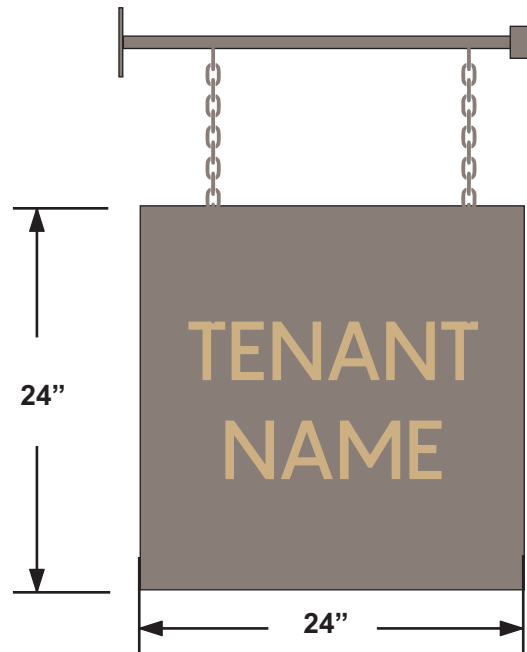

Scale: 1" = 1'-0" **4.0 sq. ft.**

FABRICATED ALUMINUM HANGING BLADE SIGN WITH FAUX FINISH. MOUNTS TO WALL AT 9'-0" ABOVE GRADE. FONT: PANAGRAM MEDIUM



Material Reference

**W1 - Wall ID**

CUT OUT ALUMINUM LETTERS  
PAINTED DURANODIC BRONZE.  
APPLIED TO EXISTING WALL.

ILLUMINATED BY LANDSCAPE LIGHTING  
RETAIL FONT: PANAGRAM MEDIUM



Scale: 3/4" = 1'-0"

24.2 sq. ft.



1.3" → DELRAY

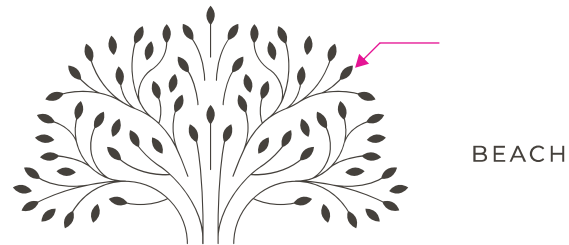

→ SUNDY VILLAGE  
3" → RETAIL TENANT    RETAIL TENANT    RETAIL TENANT

Scale: 3/4" = 1'-0"

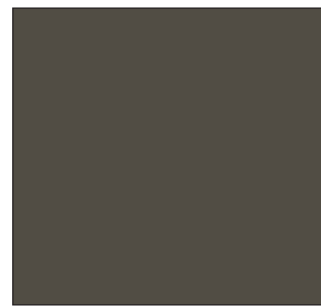

MP07458 CAST BRONZE  
MATTHEWS PAINT

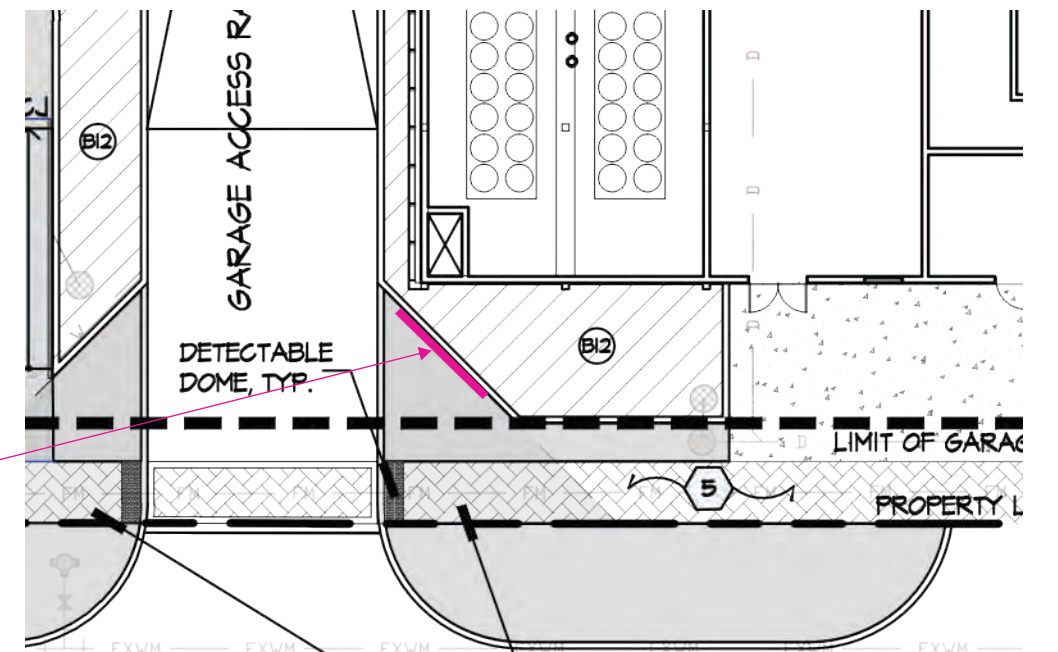

LOCATION

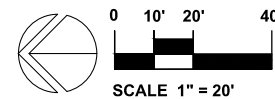

# W2 - Tenant Directory 1st Ave & Atlantic

30.0 sq. ft.

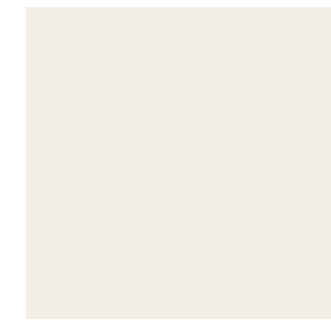
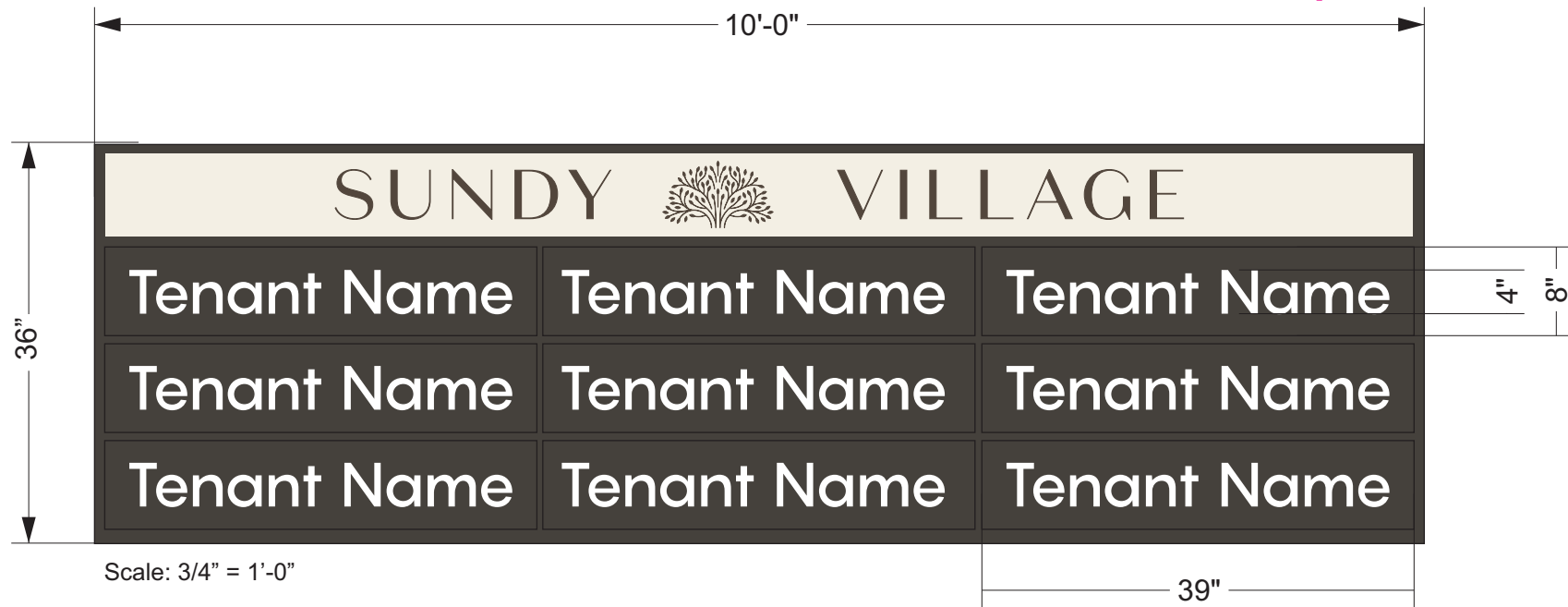

DIRECTORY SIGN FACES  
TO MATCH SW7102 FLOWER WHITE



MP07458 CAST BRONZE  
MATTHEWS PAINT

**NON-ILLUMINATED**  
2" - 6" DEEP SINGLE FACED ALUMINUM CABINET  
ALUMINUM TENANT PANELS PAINTED  
DARK BRONZE WITH FRISKIT PAINTED COPY.  
MOUNTED TO PORCH.

ILLUMINATED BY LANDSCAPE LIGHTING.

FONT: Panagram Medium





# W3 - Wayfinding Ground Mounted

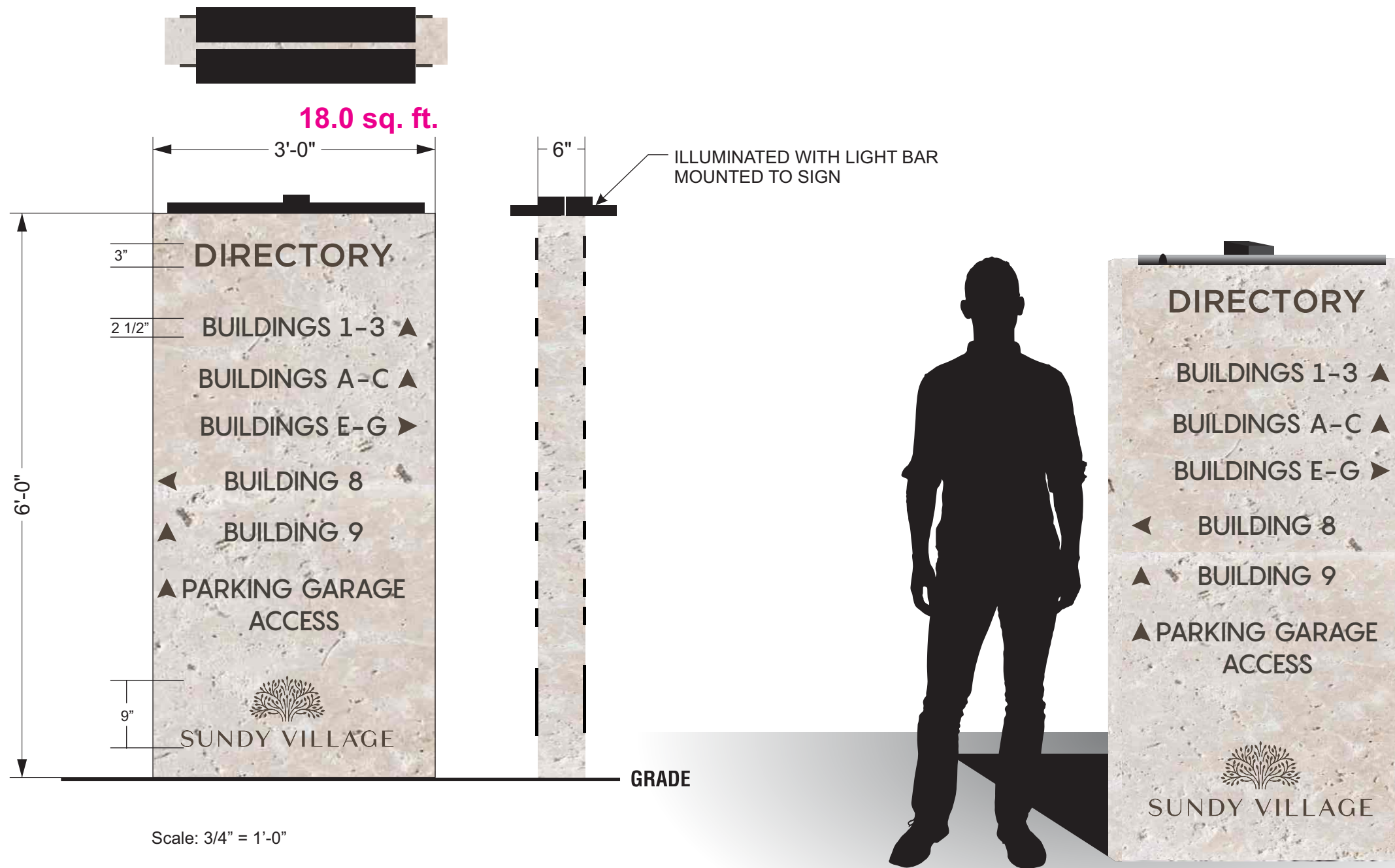

MONUMENT SIGN FACES  
CORALINA OR COQUINA  
STONE



MP07458 CAST BRONZE  
MATTHEWS PAINT

FONT: PANAGRAM MEDIUM

# W6- Restaurant Monument Sign



BUILDING C



Scale: 3/4" = 1'-0"

SIDE A:  
 NON ILLUMINATED FREESTANDING  
 MONUMENT SIGN. 3" CUT OUT ALUMINUM  
 LETTERS PAINTED BRONZE.  
 ILLUMINATED WITH GROUND LIGHTING

SIDE B: CAST BRONZE PLAQUE

FONT: PANAGRAM MEDIUM

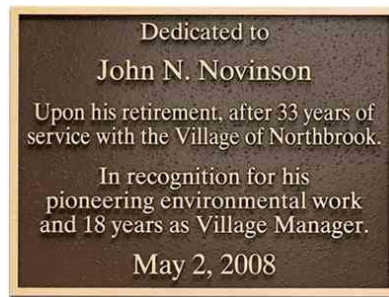

EXAMPLE OF SIGNS FOR CAST PLAQUES



MP07458 CAST BRONZE MATTHEWS PAINT



MONUMENT SIGN FACES CORALINA OR COQUINA STONE

# W7- Main Entry Monument Sign-Water Feature

Location: Swinton and Atlantic

NOTE: WATER FEATURE SIGN TO BE APPROVED BY THE CITY OF DELRAY BEACH UNDER A SEPARATE PERMIT.



DAYTIME REFERENCE

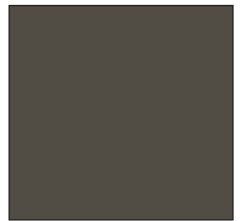

MP07458 CAST BRONZE MATTHEWS PAINT

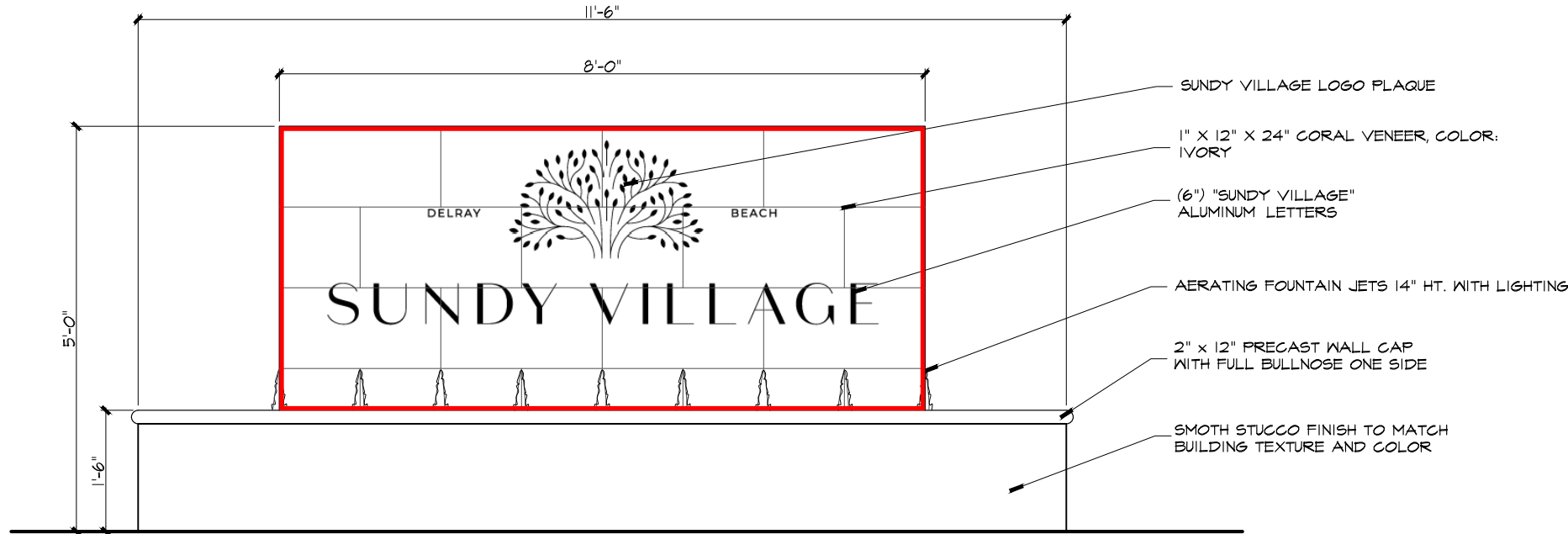

Ⓧ CIVIC PLAZA WATER FEATURE  
SCALE: 1/2" = 1'-0"

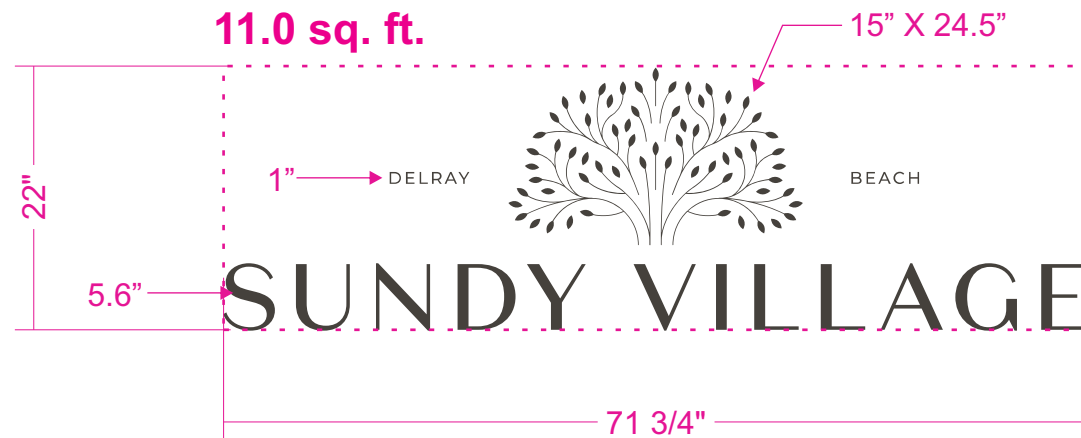

Scale: 3/4" = 1'-0"

FOUNTAIN SIGNS:  
CUT OUT ALUMINUM  
LETTERS PAINTED BRONZE.  
DOUBLE SIDED.

ILLUMINATED BY FOUNTAIN LIGHTING

# BLOCK 69 - WEST/SOUTH ELEVATION



**BLOCK 69 -PROPOSED EXTERIOR ELEVATION-EAST**  
SCALE:1/16" = 1'-0"



FOR REFERENCE

GARAGE ENTRANCE:  
DAKTRONICS OR WATCHFIRE  
OUTDOOR LED DIGITAL DISPLAY  
FULL COLOR WITH CHANGEABLE COPY  
32" X 106"

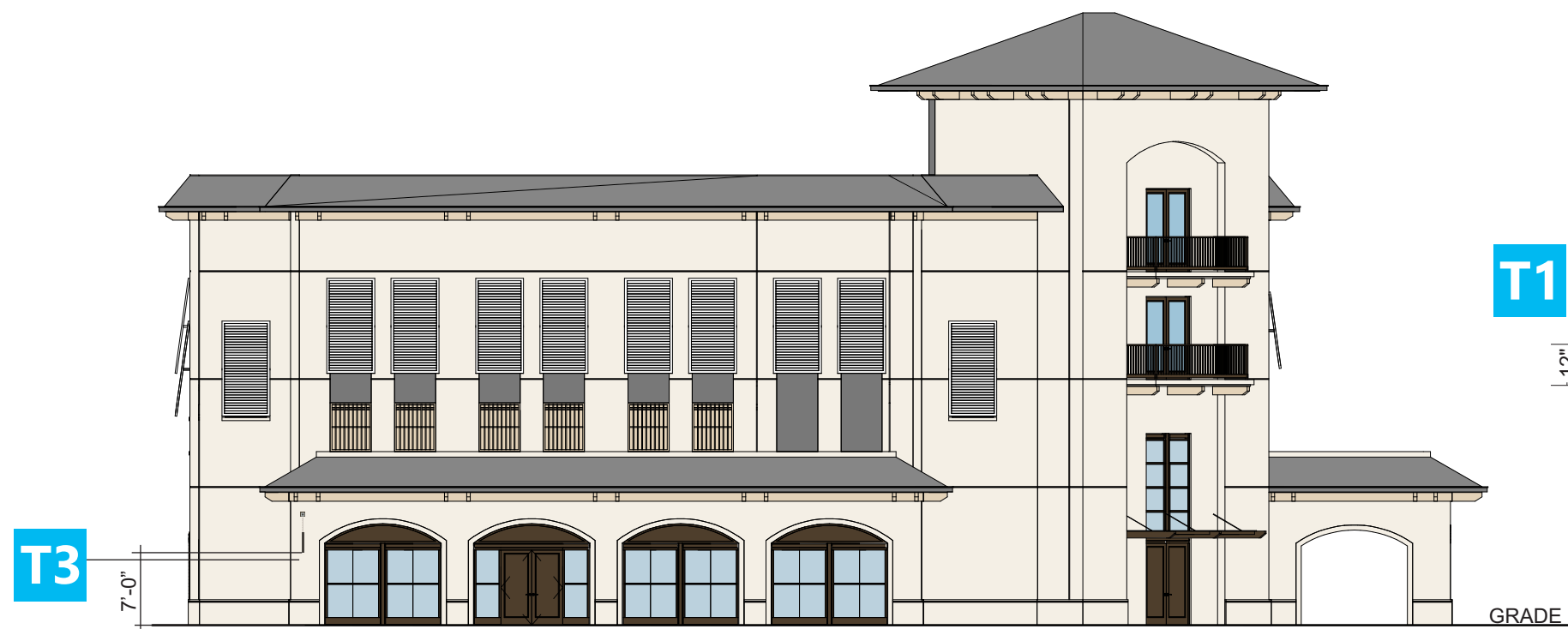

**BLOCK 69 -PROPOSED EXTERIOR ELEVATION -SOUTH**  
SCALE:1/16" = 1'-0"

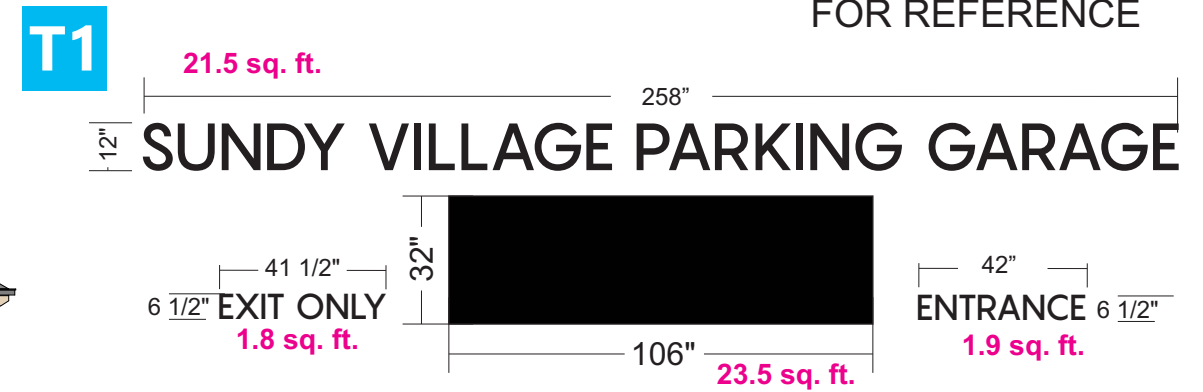

GARAGE SIGNS:  
REVERSE BACKLIT CHANNEL LETTERS  
PAINTED BRONZE.

Scale: 1/4" = 1'-0"

# T1 - Tenant ID BLOCK 70 - EAST/NORTH ELEVATION



## BLOCK 70 -PROPOSED EXTERIOR ELEVATION-NORTH

SCALE: 1" = 20'-0"



## BLOCK 70 -PROPOSED EXTERIOR ELEVATION-EAST

SCALE: 1" = 20'-0"

SIGN LOCATION-A & A2

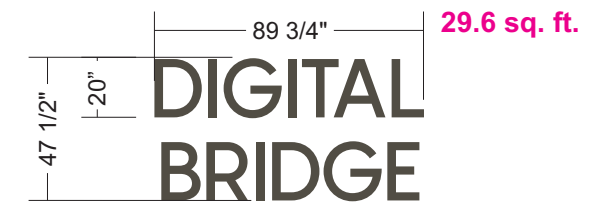

OPTIONAL LOCATION -A1 & A3

Scale: 3/16" = 1'-0"

2" DEEP REVERSE CHANNEL BACKLIT LETTERS, PAINTED BRONZE WITH WHITE LED'S

FONT: PANAGRAM MEDIUM  
Registered Trademark Fonts/logo allowed with landlord approval



# SUNDY VILLAGE

---

MASTER SIGN PLAN  
FOR REFERENCE ONLY

**B1** - Building Street Address

0123

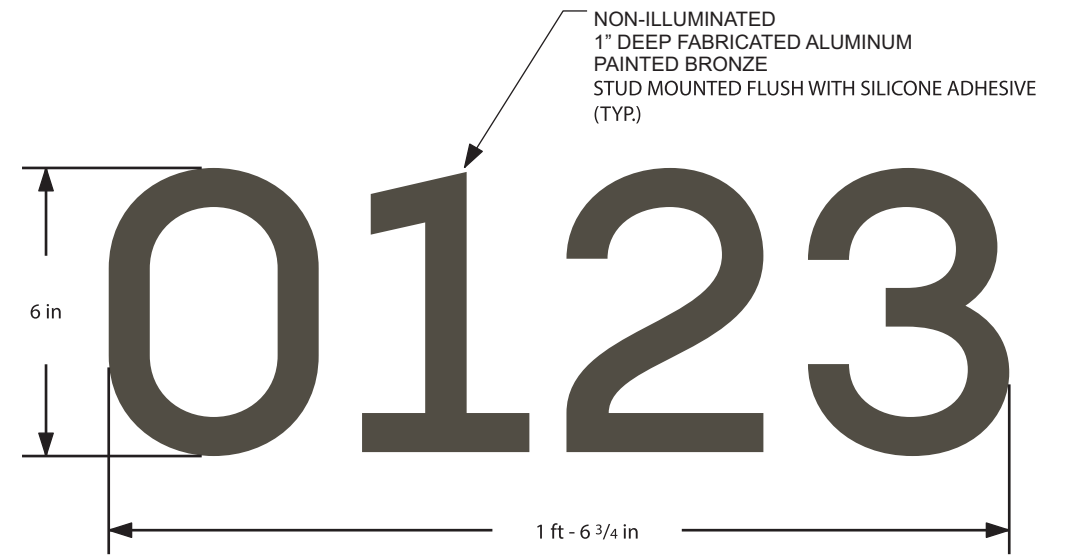

FONT: PANAGRAM MEDIUM



LETTER  
FINISH

## B2 - Building Street Address-Suite Numbers

0123

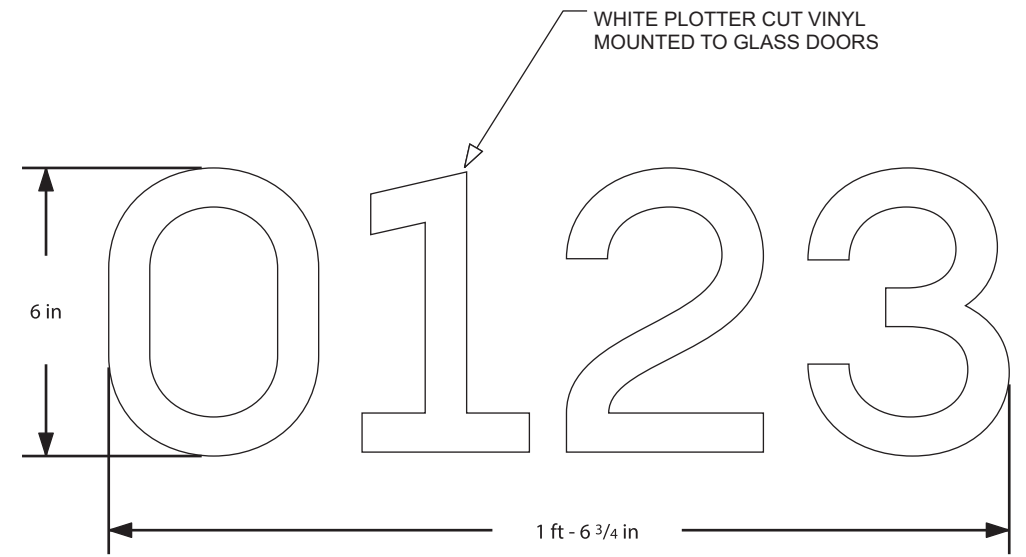

FONT: PANAGRAM MEDIUM



# G5 - Garage Parking

1.7 sq. ft.

BACKER PLATE PAINTED



MP07458 CAST BRONZE  
MATTHEWS PAINT



FONT: DOT STANDARD



# W5 - Wayfinding Directional Post Mount

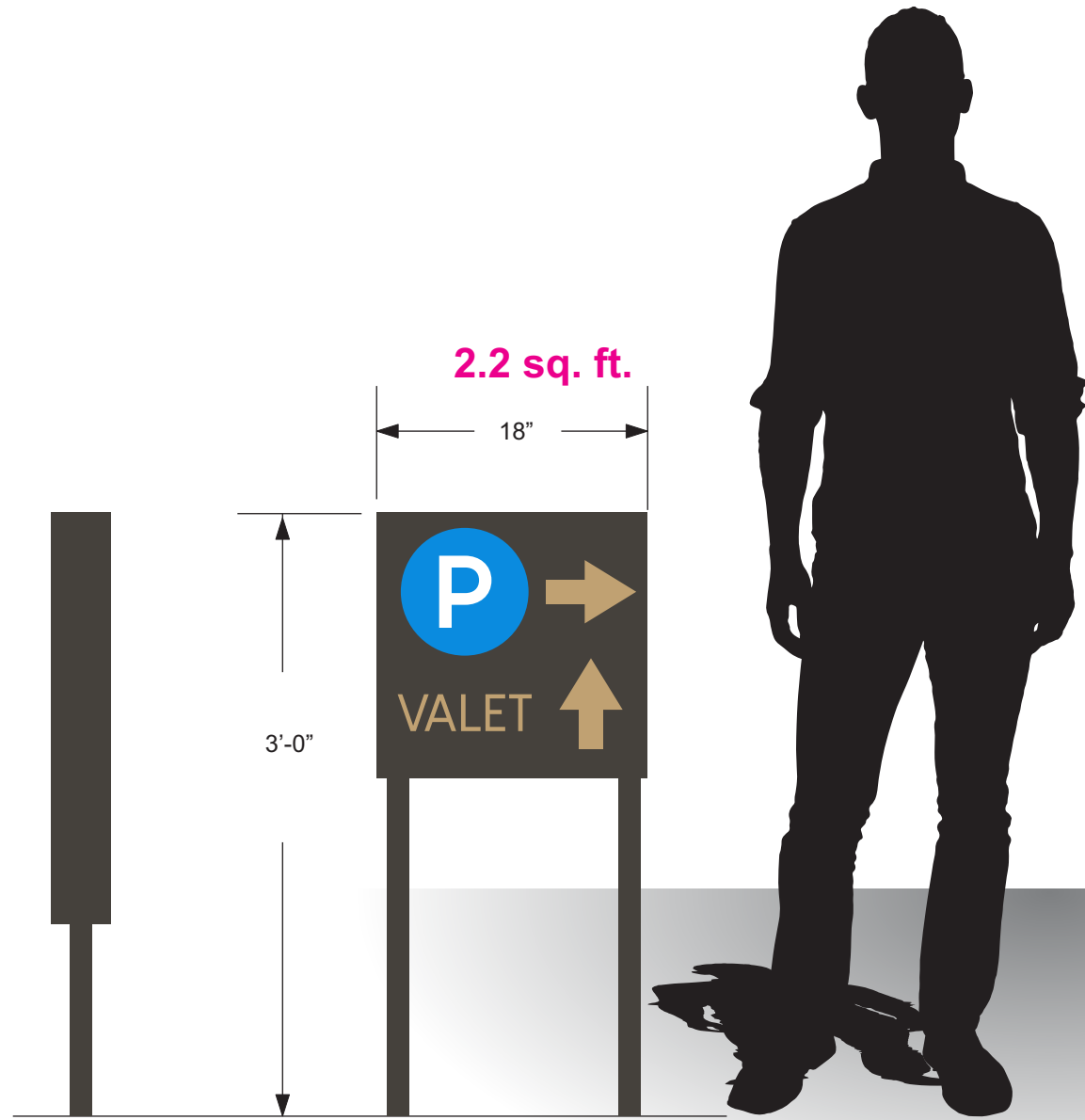

2.2 sq. ft.

18"

3'-0"

Scale: 1" = 1'-0"



MP07458 CAST BRONZE  
MATTHEWS PAINT



COPY COLOR  
PAINTED SATIN GOLD



PARKING SYMBOL  
COLOR

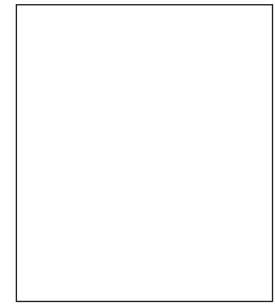

P SYMBOL  
COLOR

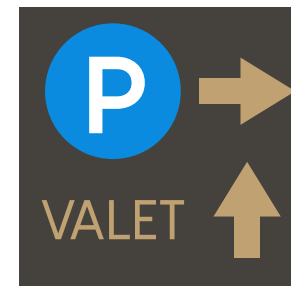

FONT: PANAGRAM MEDIUM

## H2 - Historic Information-Stand Mounted

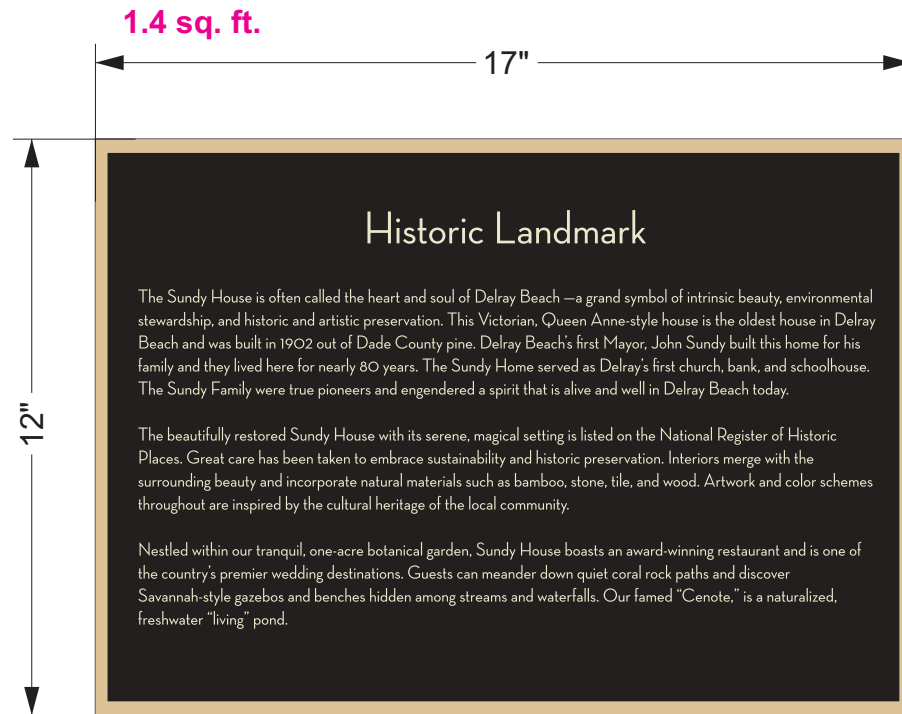

CAST BRONZE PLAQUE  
WITH OXIDIZED BORDER AND COPY.  
BACKGROUND PAINTED BRONZE.  
MOUNTS TO FABRICATED ALUMINUM STAND.

FONT: CENTURY GOTHIC

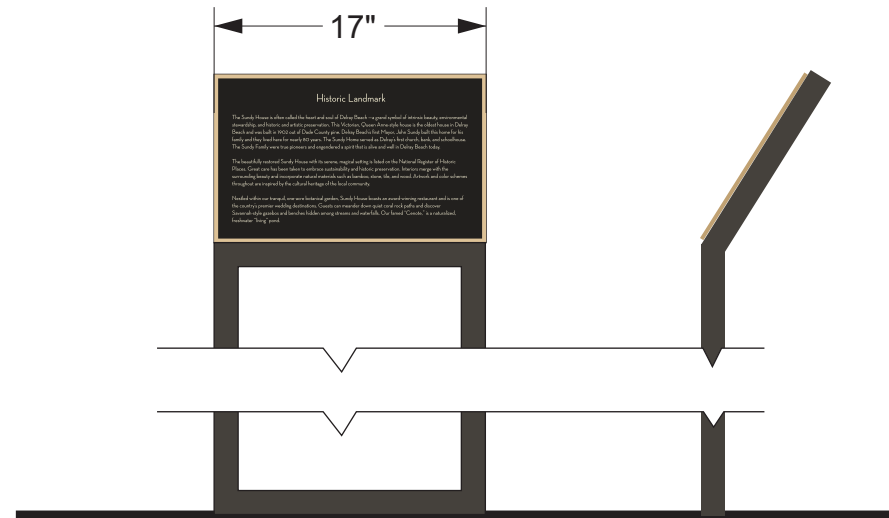

Scale: 1" = 1'-0"

MOUNTS IN LANDSCAPING



MP07458 CAST BRONZE  
MATTHEWS PAINT

## T2 - Tenant Nameplate



5/8" THICK CAST BRONZE PLAQUE WITH OXIDIZED BORDER AND COPY. BACKGROUND PAINTED DURANODIC. BLIND STUD MOUNTED TO WALL.

FONT: CENTURY GOTHIC



## T2.1 - No Smoking

.02 sq. ft.



5/8" THICK CAST BRONZE PLAQUE  
WITH OXIDIZED BORDER AND COPY.  
BACKGROUND PAINTED DURANODIC.  
BLIND STUD MOUNTED TO WALL.

FONT: CENTURY GOTHIC



## T2.2 - Large Tenant Nameplate



5/8" THICK CAST BRONZE PLAQUE  
WITH OXIDIZED BORDER AND COPY.  
BACKGROUND PAINTED DURANODIC.  
BLIND STUD MOUNTED TO WALL.

FONT: CENTURY GOTHIC



# Sundy Village Master Signage Summary

## Block 61:

Type of Sign	Zoning District	Quantity		Area (max.)		Location		Height		Illumination Type (Direct / Indirect)
		Allowed	Proposed	Allowed	Proposed	Allowed	Proposed	Allowed	Proposed	
Free Standing	OSSHAD	Up to two per lot, parcel or development	4 - W3 (Directional) 10 - W6	30 square feet per face	W3 - 18 sq. ft. W6 - 12.5 sq. ft.	may be in front yard setback	All within property except 1 W3 in setback along Swinton off sidewalk	8 feet	W3 - 6ft W6 - 5ft	W3 - Direct W6 - Indirect
	OSSHAD w. CBD Overlay	one per frontage	1 - W2.1, Atlantic Ave 1 - W3, Civic Plaza	one sign equal to half the length of the property's frontage in square feet, not to exceed 160 square. Each additional sign is limited to 50 square feet.	W2.1 - 20 sq. ft. W3 - 18 sq. ft.	None	None	14 feet	W2.1 - 4 ft. W3 - 6 ft..	W2.1 - Indirect W3 - Direct
Projecting	OSSHAD	Up to two per lot, parcel or development	9 - T3	30 square feet per face	T3 - 4 sq. ft.	from building or under canopy	from building	-	-	T3 Indirect
	OSSHAD w. CBD Overlay	one per business	8 - T3	30 square feet 3 feet from face of wall	T3 - 4 sq. ft.	from building or under canopy	from building	-	-	T3 Indirect
Under Canopy	OSSHAD	Up to two per lot, parcel or development	4 - T3 1 - G2	4 square feet per face	T3 - 4 sq. ft. G2 - 5.2 sq.ft.	under canopy	under canopy	-	-	T3 Indirect G2 - Indirect
	OSSHAD w. CBD Overlay	one per business	N/A	4 square feet per face	None	under a canopy which extends store front access		-	-	N/A
Wall	OSSHAD	Up to two per lot, parcel or development	10 - T1 1 - W1 18 - T2 (Name Plate) 1 - G1	30 square feet	T1 - 4.9-9.2 sq. ft. W1 - 24.2 sq. ft. T2 - .06 sq. ft. G1 - 38.1 sq. ft.	on building face	on building face	-	-	T1 - Direct W1 - Indirect T2 - Indirect G1 - Direct
	OSSHAD w. CBD Overlay	one per business one per building	9 - T1 1 - W7	15% of building face, not to exceed 160 square feet 9 square feet	T1 - 12.6 -15.9 sq. ft. W7 - 11 sq. ft.	facing each dedicated street frontage on rear of building not facing street	facing each dedicated street frontage	-	-	T1 - Direct W7 - Indirect
Directory	OSSHAD w. CBD Overlay	one per building	1 - W2, Atlantic Ave & SW 1st Ave (Directory)	24 square feet	W2 - 30 sq. ft.	on building face	integrated in lieu of railing	-	W2 - 3 ft.	W2 - Indirect

## Block 69:

Type of Sign	Zoning District	Quantity		Area (max.)		Location		Height		Illumination Type (Direct / Indirect)
		Allowed	Proposed	Allowed	Proposed	Allowed	Proposed	Allowed	Proposed	
Projecting	OSSHAD w. CBD Overlay	one per business	2 - T3	30 square feet 3 feet from face of wall	T3 - 4 sq. ft.	from building or under canopy	from building and under canopy	-	-	T3 Indirect
Wall	OSSHAD w. CBD Overlay	one per business one per building	one per building	15% of building face, not to exceed 160 square feet 9 square feet	Overall 96.7 sq.ft. (21.5sq.ft. T1, 1.8-9sq.ft. directional, 23.5sq.ft. informational.	facing each dedicated street frontage on rear of building not facing street	facing dedicated street frontage	-	-	Direct & Indirect

## Block 70:

Type of Sign	Zoning District	Quantity		Area (max.)		Location		Height		Illumination Type (Direct / Indirect)
		Allowed	Proposed	Allowed	Proposed	Allowed	Proposed	Allowed	Proposed	
Wall	OSSHAD w. CBD Overlay	one per business one per building	one per building or alternate of 2 per building.	15% of building face, not to exceed 160 square feet 9 square feet	Single Requested size, 29.6 sq. ft. Alternate (2), 25.6 sq. ft. each	facing each dedicated street frontage on rear of building not facing street	facing each dedicated street frontage	-	-	Direct