



DEVELOPMENT SERVICES

BUILDING | HISTORIC PRESERVATION | PLANNING & ZONING

PUBLIC ARTS ADVISORY BOARD STAFF REPORT

1880 Dr. Andre's Way

Meeting	File No.	Application Type
April 28, 2025	2025-141 (Bldg. 1880 Façade 2) 2025-016 (Bldg. 1880 Façade 3) 2025-017 (Bldg. 1880 Façade 6) 2025-020 (Bldg. 1880 Façade 9)	4 Mural Permit Applications

Property Owner	Applicant /Agent
JMS Boynton Beach	Steven Michael

Request
 Consideration of the installation of 4 murals on Building 1880 located at 1880 Dr. Andre's Way.

General Data

Location: 1880 Dr. Andre's Way

PCN: 12-43-46-18-16-000-0020

Property Size: 3.9 acres

Land Use Designation: Congress Avenue Mixed Use (CMU)

Zoning District: Mixed Residential Office Commercial (MROC)

Adjacent Zoning:

- North, South, and West – MROC
- East: Conservation District (CD) and Florida Department of Transportation (Railroad)

Existing Use: Mixed Use Commercial, Retail, Warehouse and Light Industrial



Background

The subject property is located directly west of I-95 and the FEC Railway, south of Atlantic Avenue on the east side of South Congress Avenue. The site is approximately 286 feet from S. Congress Avenue, beyond the County's Administrative Complex that is accessible by SW 2nd Street unto Dr. Andre's Way; a private access into the subject property. The 3.91-acre site, also known as "Andre's Design District" is located within the Mixed Residential Office and Commercial (MROC) zoning district and features four warehouse buildings, each with its own address, and associated parking providing 176 parking spaces. A summary of the development history is outlined below:

1979: The City Commission approved the final plat for a two-lot subdivision. Lot 1 received a Conditional Use for the McEwen Lumber Company. Additionally, a site plan was approved for the Store-All Warehouse Center Industrial Park to develop a four-building office/warehouse complex (Building A–D) with a total gross floor area of 65,075 square feet. Construction of these buildings occurred between 1981 and 1985.

1984: A site plan modification was approved to reduce the footprint of Building D (1874) from 18,000 square feet to 12,935 square feet. All four buildings are single-story structures.

1990: As part of a Citywide rezoning initiative, the property's zoning designation was changed from Light Industrial (LI) to Mixed Industrial and Commercial (MIC).

1997: The City Commission granted a Conditional Use to convert four bays, totaling 1,500 square feet located at the northeast corner of the site, to accommodate a stone cutting facility. Furthermore, the City Commission approved an amendment to the MIC zoning district regulations, reclassifying automobile paint, body, and repair shop from a Permitted use to a Conditional Use.

1998: An additional 9,785 square feet received Conditional Use approval for the establishment of automobile paint, body, and repair shops.

2004: The Public Art Advisory Board was established via Ordinance No. 77-04 with the purpose of advising and making recommendations to the City Commission on public art policy.

2007: City Commission passed Ordinance No. 5-07 to rezone the property from MIC to MROC zoning district.

2019: The current property owner acquired the four buildings with a vision to transform them into Delray's next hub for local businesses, galleries and restaurants which are permitted uses within the MROC zoning district. To attract the public to the "off the beaten path" unique mix of businesses known as "The Andre Design District", a series of murals were commissioned.

However, these murals were installed without the required mural permit approvals, in violation of the Land Development Regulations (LDR).

2022: The site became a subject to code enforcement action due to the unauthorized painting of the murals, without approval through the required mural permit process. At that time, mural installations were not permitted within the MROC zoning district.

In response, the City Commission adopted Ordinance No. 22-20, which expanded the zoning districts allowed for mural installations to include MROC, streamlining the approval process. Currently, there are 36 murals adorning the buildings, with each mural either directly associated with an individual tenant space or located on the exterior walls of the multi-bay warehouse.



It should be noted that the Code Enforcement case related to these murals remains active until all murals receive formal approval through the Public Arts Advisory Board (PAAB). Mural permit applications have been duly submitted for each building, and the murals are now scheduled for review and final action by the Board.

April 23, 2024: At the PAAB meeting, the board approved the first three murals for façades 1 and 4 on Building 1876 and façade 4 on Building 1874. The review of murals on Façade 2 of Building 1876 was postponed to a later meeting date to allow for concurrent review of all proposed murals on the same façade. This should enable the Board to determine if the murals represent a consistent theme or image.

October 29, 2024: The PAAB approved five murals on façade 2 of Building 1876.

November 26, 2024: The 13 murals located on Building 1878 were scheduled at the PAAB meeting but were postponed to the January 28, 2025 meeting.

January 28, 2025: The 13 murals located on Building 1878 were scheduled at the PAAB meeting and no action was taken due to the applicant absence.

February 13, 2025: The 13 murals remain under review by Code Enforcement Board.

February 25, 2025: The following 9 murals located on Building 1880 are scheduled for review by the PAAB.

April 28, 2025: The following 4 murals on 1880 are now before the PAAB for reconsideration

Description of Request

LDR Section 2.1.8(E)(5), Duties, powers, and responsibilities. Board Actions

The following duties, powers, and responsibilities shall be carried out by the Public Art Advisory Board: The Board shall take action on all requests for the installation of murals on property not located within a historic district or on any individually designated site listed on the Local Register of Historic Places.

LDR Section 2.1.8(F), Final Actions.

All decisions may be appealed to the City Commission, pursuant to the procedures of [Chapter 2](#).

The request is to allow 4 existing murals on building 1880 located at 1880 Dr. Andre's Way.

Pursuant to **LDR Section 8.5.3(C)(3)**, each **façade** is limited to **one** mural and may continue across a contiguous wall provided that the image or theme is consistent throughout. Each façade or surface included in the mural shall require a separate mural permit application.

Building 1880 has a total of **12 façades**. A "façade" is considered the exterior surface or face of a building. Therefore, each flat surface of the exterior wall of the building is considered a distinct façade.

Façade 10, includes 2 murals (A & B), each with its own mural permit application. The applicant since then has removed the murals and painted the surface of the wall white.

Pursuant to **LDR Section 8.5.2(A)**, the nine (9) criteria shall be utilized and a positive finding must be made for the Board to approve the requested mural applications, whether located on private or public property.

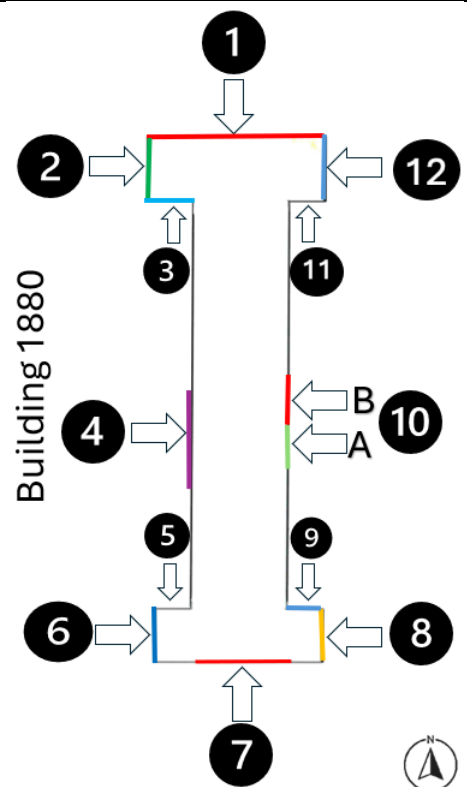

Building 1880 Façade 1 (File No. 2025-015)
Approved on February 25, 2025



Dimensions: 5 feet high by 90 feet wide (450 square feet)

The mural features a mix of abstract patterns, geometric motifs, and a tie-dye spiral, using a bold color palette of blue, pink, purple, red, and yellow. The design is fragmented by black diagonal lines, creating a patchwork effect that visually separates the various elements. While the intent may be to introduce vibrancy, the lack of thematic cohesion results in a disjointed composition that does not contribute to a unified artistic statement.

While the mural complies with Appendix A of the LDRs, meeting the definition of public art, its execution and placement raise concerns. The upper-band location isolates the artwork from pedestrian interaction, limiting its effectiveness in enhancing the site's public-facing aesthetic. Additionally, the varying artistic styles within the mural create a fragmented appearance, lacking a clear focal point or narrative cohesion.

While the mural complies with LDR Section 8.5.3(C) regarding coverage, placement, and absence of commercial messaging, its visual impact and thematic execution remain questionable. The composition appears more decorative than conceptually driven, raising the issue of whether it effectively serves the purpose of enhancing public art within the district.

Building 1880 Façade 2 (File No. 2025-141)

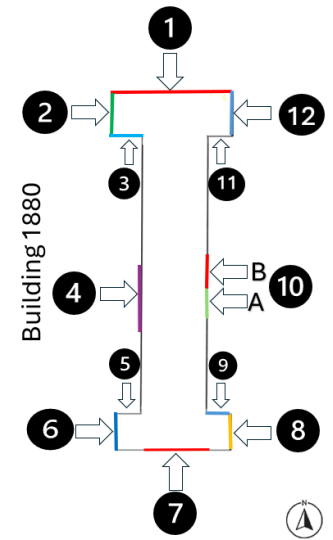

Dimensions: 12 feet high by 30 feet wide (360 square feet)

Coverage: 100% of the façade

The mural on Façade 2 spans 12 feet high by 30 feet wide (360 square feet), covering 100% of the west elevation of Building 1880. It features a stylized portrait of a blonde-haired woman wearing sunglasses and a jacket, glancing over her shoulder, set against a swirling vortex rendered in pink, green, blue, and purple tones. The composition emphasizes bold color contrasts and a strong focal figure, creating a sense of movement and depth. Unlike the historically and culturally themed murals on other façades, this artwork adopts a pop-art or fashion-inspired aesthetic, contributing to the variety of visual expressions within the overall mural collection. The mural does not incorporate text, commercial logos, or brand elements, thereby meeting the requirements of LDR Section 8.5.3(C) related to mural content and coverage.

It appears proportionate to the façade and respects the architectural features of the building. The work conforms with the definition of a mural provided in Appendix A of the LDRs, and no visual safety or illumination concerns are present. While distinct in theme from other murals on Building 1880, its scale, execution, and compliance with applicable standards support its consideration within the broader context of the Andre Design District mural program

Building 1880 Façade 3 (File No. 2025-016)



Before



Proposed

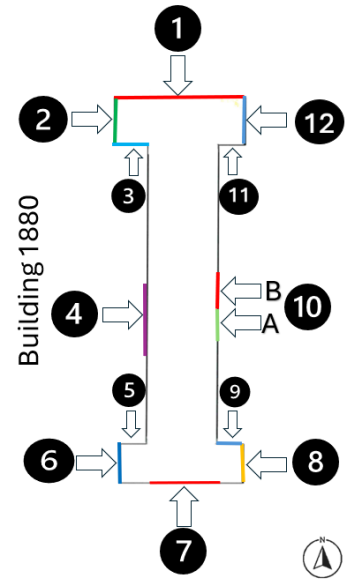

Dimensions: 12 feet high by 20 feet wide (240 square feet)

Coverage: 100% of the façade

At the PAAB meeting on February 25, 2025, the Board concluded that the text on the existing mural constituted the postponement of the mural to allow the applicant to address the concerns of the Board by graphically demonstrating the proposed change

The mural on Façade 3 spans 12 feet high by 20 feet wide (240 sq. ft.), covering 100% of the west elevation of Building 1880. It features large pink floral motifs set against a solid black background, with text previously stating “Andre Design

District” prominently displayed in bold pink uppercase letters. The mural is centered around an entrance door, incorporating a minimalistic floral arrangement that extends to the adjacent wall. The use of soft gradients and outlined shading in the flowers provides a sense of depth and movement, contrasting with the stark black background.

The integration of the commercial messaging raised concerns regarding compliance with **LDR Section 8.5.3(C)(4)**, *the mural shall be predominantly pictorial, with text limited to no more than 5 percent of the proposed mural size, except for text used to create the graphic*. The “Andre Design District” text functions as identification signage rather than an artistic component, exceeding the 5% text limit established for murals. According to LDR Section 4.6.7, text within murals that serves a commercial or branding function is classified as a wall sign, requiring a separate sign permit. The above “proposed” mural demonstrates the mural without commercial signage above to comply with the LDRs.

From a design perspective, the composition is visually simplistic, relying heavily on repetitive floral imagery without a strong narrative or thematic depth. The black background, while effective in emphasizing the pink elements, creates a stark, unfinished aesthetic, especially around architectural elements like the doorway and adjacent window. The placement of the mural does not fully utilize the façade's spatial potential, leaving significant portions of the surface unadorned and contributing to a sense of incompleteness. The floral imagery, while decorative, lacks the distinctive artistic character or conceptual intent seen in more immersive public art installations.

Additionally, the condition of the mural raises concerns about long-term maintenance. The black painted façade appears to have fading and uneven wear, which may accelerate deterioration of both the background and floral elements. The proximity to an entryway also increases the likelihood of scuffing, dirt accumulation, and weathering, particularly around the door and lower portions of the mural. Without clear maintenance commitments, the artwork risks degrading quickly, impacting its overall effectiveness as a public art feature.

While the mural partially meets LDR requirements for coverage, placement, and façade integration, its lack of thematic depth, and maintenance concerns present significant compliance issues. The overall artistic execution lacks narrative cohesion or transformative impact. This raises the question of whether the mural genuinely enhances the district's creative vision or simply serves as a stylized branding tool for the development.

Building 1880 Façade 6 (File No. 2025-017)



Before

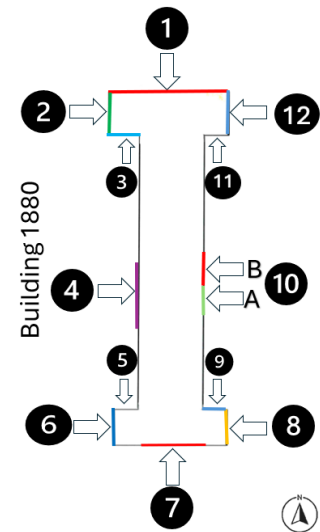

Dimensions: 12 feet high by 30 feet wide (360 square feet)

Coverage: 100% of the façade

At the PAAB meeting on February 25, 2025, the Board concluded that the logos on the existing mural constituted the postponement of the mural to allow the applicant to the address the concerns of the Board by graphically demonstrating the proposed change.

The mural on Façade 6 spans 12 feet high by 50 feet wide (600 square feet), covering 100% of the west elevation of Building 1880. It features a purple Chevrolet Impala in motion, set against a beach-inspired background with mechanical and automotive imagery. The mural includes a large transmission illustration, multiple automotive brand logos, and industrial gear motifs, creating a



Proposed

1880. It features a purple Chevrolet Impala in motion, set against a beach-inspired background with mechanical and automotive imagery. The mural includes a large transmission illustration, multiple automotive brand logos, and industrial gear motifs, creating a

dynamic yet visually fragmented composition. Above the artwork, a wall-mounted sign reading "Performance Transmission" is prominently displayed.

The Performance Transmission sign is non-conforming and lacks a permit, making it a violation of the sign code under **LDR Section 4.6.7(B)**, *it shall be unlawful for any persons to post, display, change, or erect a nonexempt sign or a sign structure, that requires a permit, without first having obtained a permit therefor. Signs or sign structures erected without a valid permit shall be deemed in violation and it shall be mandatory to obtain a permit, based on this Section, or else remove the sign or sign structure.* The MROC zoning district only allows wall signs if they face a dedicated street or I-95. Since this sign does not meet either requirement, it is not permitted and must be removed. Furthermore, it does not qualify as a building sign under the code since it functions as a commercial advertisement for the automobile repair shop rather than an architectural element.

The inclusion of automotive brand logos such as Chevrolet, Honda, Ford, Audi, and Dodge constitutes a direct violation of the definition of a mural which strictly prohibits incorporating brand names, logos, trademarks, or commercial messaging. According to the United States Patent and Trademark Office (USPTO), the automotive brand logos displayed on the right side of the mural are all registered trademarks as depicted in the "before" image. As a result, the applicant has removed all the trademark logos from the mural as a condition of approval to ensure compliance with LDR mural regulations as shown in the "proposed" image.

From an artistic standpoint, the mural demonstrates technical skill, particularly in shading, reflections, and depth. However, its composition is cluttered, with competing elements—beach scenery, mechanical components, and corporate branding—lacking thematic cohesion. The coexistence of realistic and abstract styles further contributes to visual disarray, making the mural appear more promotional than expressive. The use of bright yellow, pink, and blue hues in the background creates a chaotic visual effect, which detracts from the overall quality of the piece.

The placement of the mural also presents challenges. The non-conforming sign disrupts the visual flow of the artwork, functioning more like a billboard than an integrated artistic element. The dark blue background of the sign contrasts awkwardly with the sky, creating an unintended separation that breaks the continuity of the design. Additionally, the low positioning of the artwork near the pavement makes it susceptible to wear, fading, and potential vandalism over time. The blue cloud-like outline surrounding the sign diminishes the mural's aesthetic integrity, further weakening its effectiveness as a cohesive public art installation.

Building 1880 Façade 7 (File No. 2025-018)
Approved on February 25, 2025

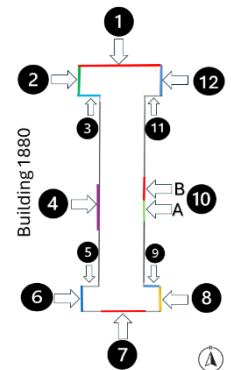
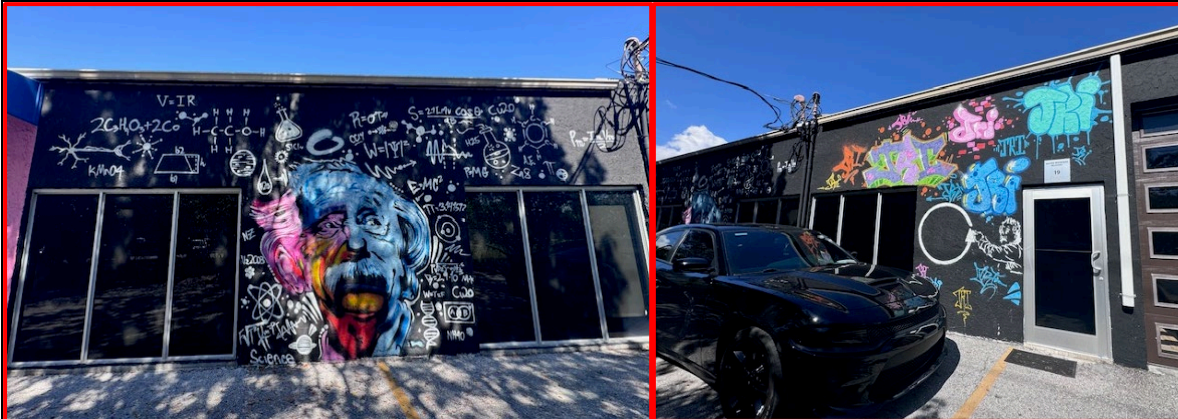

Dimensions: 12 feet high by 90 feet wide (1,080 square feet)
Coverage: 75% of the façade

The mural on Façade 7 spans 12 feet high by 90 feet wide (1,080 square feet), covering approximately 75% of the south elevation of Building 1880. The mural prominently features a stylized portrait of Albert Einstein, rendered in a mix of blues, reds, dark and light pinks, and yellows, with a black background enhancing contrast and depth in Einstein's facial features. Surrounding the portrait are mathematical equations and scientific symbols, reinforcing his contributions to quantum mechanics and theoretical physics.

However, the right portion of the façade previously contained a graffiti-style mural featuring the letters "JRI" and various colorful graffiti tags, which were separate from the Einstein artwork. As seen in the "Before" image, the JRI mural had a distinct composition, with multiple overlapping lettering styles, bright neon colors, and a spray-paint aesthetic, making it stylistically disconnected from the Einstein mural. Since then, the "JRI" graffiti elements have been removed, but their prior existence raises questions regarding compliance and the intended artistic cohesion of the façade.

Per LDR Section 8.5.3(C)(3), *each façade is limited to one mural*, although a consistent image or theme may continue across a contiguous wall. Given the clear stylistic and thematic disconnect between Einstein's portrait and the now-removed graffiti lettering, there is a strong argument that this façade previously contained two separate murals rather than a single, unified artistic statement. If the graffiti lettering was originally considered a separate artistic installation, it should have required a separate mural permit to comply with the regulations.

While the removal of the "JRI" graffiti elements has improved thematic unity, remnants of the prior mural may still be present, requiring clarification on whether the applicant intends to repaint or restore the affected area. The Public Art Advisory Board must evaluate whether the modifications made to Façade 7 sufficiently align with the original permit request or if additional approvals are necessary.

From an artistic standpoint, the Einstein mural demonstrates a high level of technical skill, particularly in its use of color gradients, lighting effects, and expressive detailing. The mathematical notations and scientific symbols add a layer of intellectual depth, reinforcing Einstein's legacy as a physicist. However, the black background and exposed location raise concerns about long-term maintenance, as dark paint is prone to fading and accumulating dirt. The vibrant colors in Einstein's face may also be susceptible to sun exposure, requiring periodic restoration. A clear maintenance plan must be in place to ensure the mural retains its visual quality over time.

Overall, while the Einstein portion of the mural meets the artistic and thematic criteria of public art, the previous presence of the "JRI" graffiti mural raises compliance concerns. The Board must determine whether the removal of the graffiti elements sufficiently resolves the issue or if further action is needed to ensure full regulatory alignment with mural permit requirements.

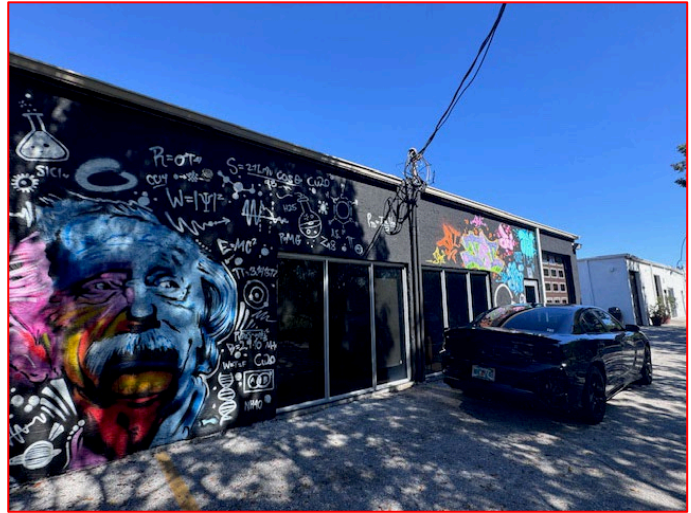

Building 1880 Façade 8 (File No. 2025-019)
Approved on February 25, 2025

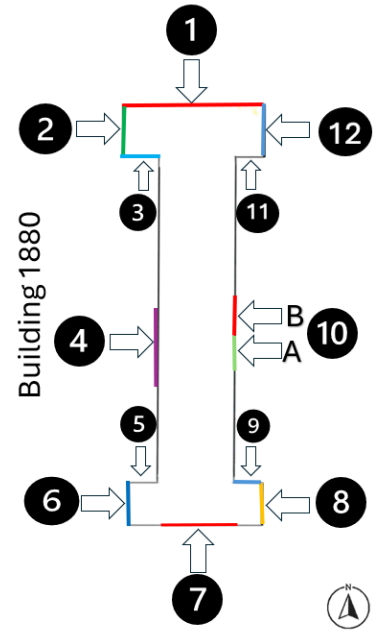

Dimensions: 12 feet high by 30 feet wide (360 square feet)
Coverage: 100% of the façade

The mural on Façade 8 spans 12 feet high by 30 feet wide (360 square feet), covering 100% of the east elevation of Building 1880. The mural features portraits of four prominent historical figures, each depicted in a distinct background color—blue, pink, green, and yellow—creating a visually striking composition. The subjects appear to be individuals of great cultural and historical significance, symbolizing leadership, activism, and justice.

From an artistic standpoint, the mural demonstrates strong composition and technical skill, particularly in its use of bold color blocking and expressive brushwork to capture the likeness of each figure. The choice of vivid, contrasting colors enhances the mural's visual impact and thematic clarity, ensuring that each figure stands out while maintaining a sense of cohesion within the overall piece. The stylized rendering of facial features and clothing details contributes to the mural's recognizability and cultural depth.

However, while the mural meets artistic and regulatory standards, maintenance concerns arise due to its exposed location and bold color palette. The intensity of the colors may be susceptible to fading, particularly under direct sunlight, which could diminish the mural's vibrancy over time. Additionally, the paint application appears to extend around building elements such as pipes and window edges, which may result in wear and inconsistencies if the mural is not properly sealed or maintained.

Building 1880 Façade 9 (File No. 2025-020)

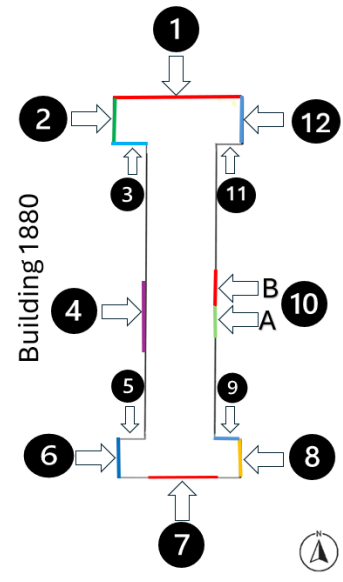

Dimensions: 12 feet high by 20 feet wide (240 square feet)
Coverage: 100% of the façade

The mural on Façade 9 spans 12 feet high by 20 feet wide (240 square feet), covering 100% of the east elevation of Building 1880, located on the south portion of the building facing north. The artwork consists of a top-view of a brain delineated by half multi-color with graffiti type splatter in the background and the other half black and white with a combination of abstract patterns, digital-inspired

graphics, and text elements on a black background, incorporating symbols, graphs, flowcharts, and interconnected nodes that resemble social media networks, digital interaction, and technological themes.

The image expresses the analytical and logical thinking of the brain's left hemisphere by the arrangement of symbols and text. The inclusion of words such as "Interaction," "Identity," "Subscribers," and "Rank Social" raises concerns regarding potential thematic ambiguity, as the mural blurs the line between conceptual art and informational design.

Per LDR Section 8.5.3(C)(3), each façade is limited to one mural, and while this piece appears to be a single composition, the varied design elements and scattered text create an unstructured visual hierarchy, potentially diminishing its effectiveness as a public art installation. Additionally, the text components must comply with LDR Section 8.5.3(C)(4), which limits text in murals to no more than 5% of the overall mural size, unless incorporated as part of a graphic design. The prominent use of words and labels throughout the mural may exceed this limit. In addition, the presence of detailed line work and small-scale text elements further increases the risk of deterioration, particularly in high-exposure areas. Without a structured maintenance plan, portions of the mural may fade unevenly, compromising its readability and artistic impact.

While the right side of the image expresses the product of the right hemisphere of the brain which is considered to be creative thinking, artistic expression, emotions, and imagination. The image further expresses this impression by the multi-color splatter as the background, given the feeling of an explosive creative idea.

Overall, while the mural aligns with the definition of public art under Appendix A of the LDRs, its lack of a cohesive composition, potential text compliance issues, and long-term durability concerns warrant further evaluation by the Public Art Advisory Board. The Board should assess whether modifications are necessary to enhance the mural's thematic clarity, ensure text compliance, and establish a maintenance strategy that preserves the integrity of the artwork over time.

Building 1880 Façade 10A (File No. 2025-021)



Before



After

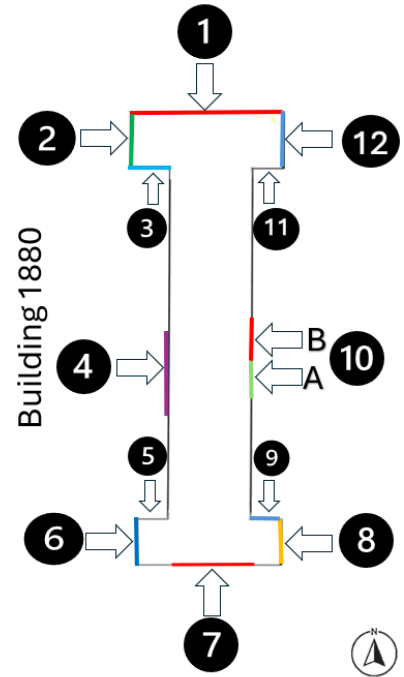

Proposed -

Dimensions: 12 feet high by 5 feet wide; 8 feet by 5 feet above window (100 square feet)
Coverage: 100% of the façade

The mural on Façade 10A spans 12 feet high by 5 feet wide, with an additional 8 feet by 5 feet section above a window (100 square feet total). The "Before" image showcases a bold, colorful eye symbol within a lotus-like design, accompanied by text elements, including "ZEK BROWS Studio" and the phrase "#youareenough". The "After" image shows significant alterations to the façade, with most of the previous mural removed or painted over in a muted blue tone. The applicant has since painted over the wall surface, thus removal of the previous mural and paint color.

Building 1880 Façade 10B (File No. 2025-022)

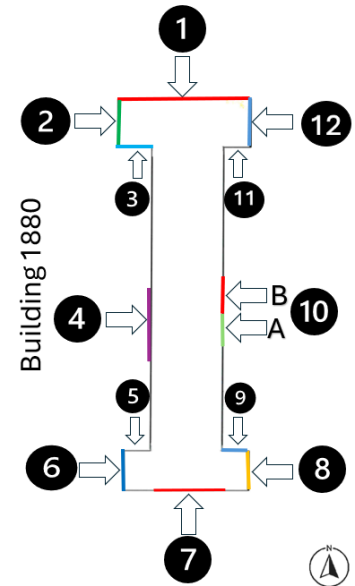

Dimensions: 12 feet high by 20 feet wide (240 square feet)
Coverage: 100% of the façade

The mural on Façade 10B spans 12 feet high by 20 feet wide (240 square feet), covering 100% of the east elevation of Building 1880. The "Before" image showcases a bold, colorful eye symbol within a lotus-like design, accompanied by text elements, including "ZEK BROWS Studio". The background consisted of a pastel gradient, blending pink, teal, and white tones to create a visually soft yet impactful message. The mural was impacted by significant water damage. Due to the damage, the applicant has repaired the wall and has painted the wall color back to its original color, therefore, no mural is proposed.

Building 1880 Façade 12 (File No. 2025-023)
Approved on February 25, 2025

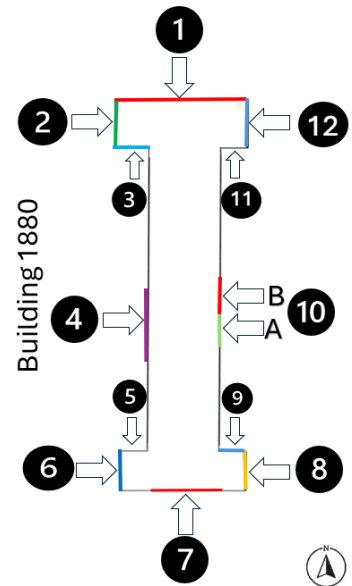

Per LDR Section 8.5.3(C)(3), each façade is limited to one mural, though a consistent image or theme may continue across contiguous walls. This mural qualifies as a single, cohesive artistic statement, successfully integrating multiple cultural and historical references into one narrative of unity and resilience. However, the noticeable deterioration raises concerns regarding maintenance and longevity, which must be addressed per LDR Section 8.5.3(C)(7), requiring a preservation and maintenance plan to ensure the mural retains its integrity.

Additionally, LDR Section 8.5.2(A)(4) requires public art to be of exceptional quality and enduring value. While the original execution demonstrated a high level of artistry, the current condition suggests inadequate maintenance, which could diminish its intended long-term cultural and aesthetic contribution. The Public Art Advisory Board may need further clarification on restoration efforts or protective measures planned to prevent further degradation.

From a technical standpoint, the vivid color palette and intricate details require a stable surface and proper protective coatings to prevent fading, chipping, and weather-related wear. Without proactive upkeep, the mural risks further loss of detail and artistic impact over time. The Board should assess whether the existing maintenance plan is sufficient or if additional measures, such as resealing and periodic touch-ups, should be mandated.

Overall, while the mural on Façade 12l meets artistic and thematic criteria for public art, its current state of deterioration raises significant maintenance concerns. The Board must determine whether restoration efforts should be required to preserve its cultural significance, artistic integrity, and compliance with mural preservation standards.

Mural Analysis

A thorough analysis of each mural is provided in the individual mural reviews. There are specific criteria for the Board to consider when taking action on mural requests. The following board criteria and technical criteria are listed below.

LDR Section 8.5.2(A) – Criteria for Board Action.

The following guidelines are to be utilized when making a recommendation or acting on a request for the installation of public art, whether located on private or public property: If the following criteria are not met, the application shall be disapproved:

- (1) Whether the proposed public art conforms to the definition of public art;

- (2) *Whether the proposed public art is compatible with the neighborhood and not injurious to the neighborhood or otherwise detrimental to the public welfare;*
- (3) *Whether the proposed public art presents a safety hazard to the public;*
- (4) *Whether the proposed public art is of exceptional quality and enduring value;*
- (5) *Whether the proposed public art serves to further the City's goal of promoting cultural diversity;*
- (6) *Whether the proposed public art is appropriate to the site;*
- (7) *Whether the proposed public art should be installed at the proposed location on a site or at a different location;*
- (8) *Whether the proposed public art requires extraordinary maintenance, such as any special servicing due to periodic adjustment, repairing, or repair or replacement of moving parts.*
- (9) *Whether the proposed public art conforms with all other applicable aspects of the LDRs.*

The following analysis is provided that includes the board criteria listed above, and the technical criteria listed below.

LDR Section 8.5.3(A), Location

Murals may be proposed on a façade, flat top roof, parking deck, perimeter walls or fences, or dumpster enclosures of any building or structure on a property not located in a historic district or individually designated on the Local Register of Historic Places but that:

- (a) *Faces a railroad right-of-way;*
- (b) *Faces Interstate 95;*
- (c) *Is located within the Central Business District (CBD), Community Facilities (CF), Industrial (I), Light Industrial (LI), Mixed Industrial and Commercial (MIC), **Mixed Use Residential Office and Commercial (MROC)**, General Commercial (GC), Planned Commercial (PC), Neighborhood Commercial (NC), Planned Office Commercial (POC), Professional Office District (POD), Open Space and Recreation (OSR), or Special Activities District (SAD) zoning districts.*

The subject property is located within the MROC zoning district and features a warehouse building, specifically Building 1878. Although this building does not directly face either a railroad right-of-way or Interstate 95, the property in its entirety does front the FEC Railway and Interstate 95 is directly to the east of the railway.

LDR Section 8.5.3(B), Design and installation

Each mural shall be designed and installed with techniques and/or materials that do not permanently damage the facade of the building. Murals are also subject to compliance with the applicable requirements of the Florida Building Code any other applicable local, state, or federal regulations.

LDR Section 8.5.3(C), Placement and Design requirements

All murals must meet the following requirements:

- (1) **Coverage, size, and scale.** *Murals shall be proportionate in size and scale to the building facade. A mural may cover 100 percent of the wall, provided it does not paint over windows.*
- (2) **Façade features.** *Murals shall be positioned on the façade in a manner that respects architectural features. Murals shall not cover windows or mask architectural details in a manner that detracts from the architecture of the building.*
- (3) **Mural limitations.** *Each facade or surface of a building or accessory structure shall have only one mural. A consistent image or theme may continue across contiguous walls; however, each facade or surface included in the mural shall require a separate mural permit.*
- (4) **Mural text size.** *The mural shall be predominantly pictorial, with text limited to no more than 5 percent of the proposed mural size, **except for text used to create the graphic.***
- (5) **Signage and commercial messaging.** *Signage and commercial messaging in murals are regulated in accordance with Section 4.6.7.*

- (6) **Illumination.** Murals may be illuminated only by indirect lighting. Any proposed illumination shall be accompanied by a photometric plan as set forth in Section 2.4.3(B)(17) that demonstrates compliance with Section 4.6.8. Illumination shall not continue after 11:00 pm. Internal illumination, blinking lights, and flashing lights are prohibited.
- (7) **Preservation and maintenance.** Applicants must provide a preservation and maintenance plan for the proposed mural.
- (8) **Public safety.** Mural faces may not have any moving or animated parts, or any other electronic movements. Murals may not be illuminated in such a manner so as to cause glare or to impair the vision of motorists or otherwise distract motorists and interfere with their ability to safely operate their vehicles.
- (9) **Compliance with laws.** Murals must comply with all applicable laws, rules and regulations of the federal, state and county governments. Any proposed amendments to this section must be consistent with applicable federal, state and county laws and ordinances in effect at the time of such amendment.

Appendix A of the LDR defines a “mural” as “an original, one-of-a-kind unique mosaic, painting, or graphic art or combination thereof (including collage effects) that is professionally applied to aesthetically enhance the exterior of a building or accessory structure such as a dumpster enclosure, fence, or site wall, **that does not contain any brand name, product name, letters of the alphabet spelling or abbreviating the name of any product, company, profession, or business, or any logo, trademark, trade name, or other commercial message.**”

The mural regulations allow text on murals provided that the text size does not exceed 5% of the total mural size and meets the definition of a mural.

In addition, Appendix A provides a definition of a “**painted wall sign**” which is defined as “a sign applied with paint or similar substance on the face of a wall.” Furthermore, a “**wall sign**” is defined as “a **sign painted** or attached parallel to the outside of a building”. Therefore, any letters applied by paint are considered a wall sign and shall be subject to the Sign Code regulations set forth in Section 4.6.7.

Pursuant to Table 4.6.7(A), Sign standards per zoning district, the MROC zoning district allows various sign types. One type of signage allowed is a wall sign which is restricted to one wall sign per business that faces a dedicated street frontage or facing I-95 and one wall sign per building restricted to 9 square feet to the rear of the building not facing a street. As the subject property does not face any streets or I-95, the subject property is limited to only one wall sign per building, not including the other various sign types such as directory, projecting, under canopy or free-standing sign.

The applicant has provided a detailed maintenance plan for the murals, which includes biannual visual assessments to check for signs of fading, chipping, cracking, vandalism, or other damages. In addition, minor repairs will be addressed promptly with touch-ups for fading, damage or vandalism within 72 hours of identification. The maintenance plan also outlines an annual cleaning schedule for removing dirt, dust, and pollutants from all murals, with a protective clear coat or sealant reapplied to safeguard the murals against environmental factors. The proposed murals do not include any electronic components, animated parts or any illumination that would cause glare to impair or distract the vision of motorists from the ability to safely operate their vehicle

The murals were the creation of Denny Graff, an established artist with experience in graffiti art, murals, acrylic painting, and design. His work can be found in prominent locations like Orlando and Wynwood. He began as a graffiti artist on the streets. He is known for his unique ability to blend urban grit with contemporary art. Graff's comprehensive Biography is attached.

Objective NDC 1.4 Industrial Land Use Designations

Apply the industrial land use designations of Industrial and Commerce to those areas where industrial type uses, such as fabrication and assembly of goods, warehousing, and vehicle repair, are the primary economic strategy for the district, to ensure that those industries, which are essential to the local economy, are appropriately accommodated in the city.

Overall, Andre Design District has a total of 31 existing murals spread across four warehouse buildings, illustrating various murals. Per Appendix A of the LDRs, “**Public Art**” is defined as “a means of artwork or works of art including, but not limited to sculptures, integrated architectural or landscape architectural work, community art, digital media installations, or murals....”

The subject property is surrounded by industrial use to the north and the County’s Administrative Complex to the west and south within the Congress Avenue Corridor with a Congress Avenue Mixed Use (CMU) land use designation. The vision for the Congress Avenue Corridor is to offer new development and redevelopment with a mix of commercial, industrial, office, and residential uses with a cohesive aesthetic for the corridor.

OBJECTIVE HCE 3.6 Design & Social Interaction
Encourage new developments to promote social interaction through site design.

Policy HCE 3.6.3
Encourage the provision of public art and preserve and increase access to cultural resources.

A similar redevelopment strategy has been taking wave through industrial zoned districts such as Wynwood in Miami to revitalize the neighborhood after a mass exodus of residents leaving behind abandoned warehouses. The transformation began for the neighborhood in the early 2000s by a real estate developer who bought the properties. Wynwood has since evolved into one of the most prominent creative communities in the United States, and a global destination for art, fashion, and innovation.

In 2019, the current property owner acquired the four buildings with a vision to transform them into Delray’s next hub for local businesses, galleries and restaurants which are permitted uses within the MROC zoning district. The purpose was to attract the public to the “off the beaten path” offering a unique mix of businesses known as “The Andre Design District”. At that time, the commissioning of the existing murals existing today was pursued.

The Comprehensive Plan highlights the importance of allowing public art, preserving and increasing access to cultural resources. It promotes strategic partnerships with those involved with the creative arts to establish policies and programs that enhance Delray Beach as a diverse City through cultural attractions, traditions, communities and business districts. The plan also identifies synergies between these clusters of cultural and innovation districts to encourage economic development in mixed use centers and neighborhoods.

Delray Beach is rich in cultural history, and the vision for the city includes preserving the existing cultural districts, market and brand cultural attractions and traditions. Meanwhile, identifying new opportunities for additional cultural district, allow public arts and expand by creating innovation districts to grow the clusters to create economic prosperity in mixed use centers and neighborhoods.

The creation of a new cultural or innovation district through the commissioning of these murals in the “Andre Design District” aligns with the vision of the Comprehensive Plan provided that this initiative improves the quality of life of Delray Beach residents.

The Board shall consider whether the proposed public art is compatible with the surrounding neighborhood, created with exceptional quality and enduring value that serves the City’s goal of promoting cultural diversity and identifies as an opportunity to create an innovation district to grow and encourage economic development. The Board shall also consider if the expansion of the public art which is typically found downtown is appropriate to this site or should be located at a different location. Additionally, the Board shall consider if the 2 existing murals on the east elevation on façade 10A and 10B constitute separate images or form one consistent theme or image or meets the definition of a mural. The Board shall further consider the existing non-compliant signage incorporated into the existing murals and the deteriorated and peeling murals for action.

Policy NDC 1.4.9
Analyze the existing land use and zoning designations of Commerce and Congress Avenue Mixed Use assigned to property along the Congress Avenue Corridor for the purpose of accommodating a balanced mix of commercial, industrial, office, and residential uses with a cohesive aesthetic for the corridor.

Objective SPE 2.1 Private and Nonprofit Organizations
Increase efforts to build new public-private partnerships and expand existing partnerships to improve the quality of life for Delray Beach residents.

Policy SPE 2.1.9
Coordinate with private partners involved in the creative arts to establish policies and programs in building a cultural master plan. [Complete by 2025]

Objective ECP 3.2 Cluster Marketing
Market and brand Delray Beach focused on the synergies of its industry clusters.

Policy ECP 3.2.6
Promote Delray Beach as a diverse city highlighting cultural attractions, traditions and communities in neighborhoods and business districts as well as downtown.

Policy ECP 3.3.2
Identify opportunities for potential zones, cultural districts or innovation district to grow the clusters and encourage economic development in mixed-use centers and neighborhoods.

Optional Board Actions

Façade 2 (File No. 2025-141)

- A. Move approval, of the Mural Permit (2025-141) to paint a mural (façade 2) on the west elevation of Building 1880 located at **1880 Dr. Andre's Way**, by finding that the request is consistent with the Comprehensive Plan and meets criteria set forth in Chapter 8 of the Land Development Regulations.
- B. Move approval, as amended, of the Mural Permit (2025-141) to paint a mural (façade 2) on the west elevation of Building 1880 located at **1880 Dr. Andre's Way**, by finding that the request is consistent with the Comprehensive Plan and meets criteria set forth in Chapter 8 of the Land Development Regulations.
- C. Move denial, of the of the Mural Permit (2025-141) to paint a mural (façade 2) on the west elevation of Building 1880 located at **1880 Dr. Andre's Way**, by finding that the request is inconsistent with the Comprehensive Plan and meets criteria set forth in Chapter 8 of the Land Development Regulations
- D. Postpone

Façade 3 (File No. 2025-016)

- A. Move approval, of the Mural Permit (2025-016) to paint a mural (façade 3) on the west elevation of Building 1880 located at **1880 Dr. Andre's Way**, by finding that the request is consistent with the Comprehensive Plan and meets criteria set forth in Chapter 8 of the Land Development Regulations.
- B. Move approval, as amended, of the Mural Permit (2025-016) to paint a mural (façade 3) on the west elevation of Building 1880 located at **1880 Dr. Andre's Way**, by finding that the request is consistent with the Comprehensive Plan and meets criteria set forth in Chapter 8 of the Land Development Regulations.
- C. Move denial, of the of the Mural Permit (2025-016) to paint a mural (façade 3) on the west elevation of Building 1880 located at **1880 Dr. Andre's Way**, by finding that the request is inconsistent with the Comprehensive Plan and meets criteria set forth in Chapter 8 of the Land Development Regulations
- D. Postpone

Façade 6 (File No. 2025-017)

- A. Move approval, of the Mural Permit (2025-017) to paint a mural (façade 6) on the west elevation of Building 1880 located at **1880 Dr. Andre's Way**, by finding that the request is consistent with the Comprehensive Plan and meets criteria set forth in Chapter 8 of the Land Development Regulations.
- B. Move approval, as amended, of the Mural Permit (2025-017) to paint a mural (façade 6) on the west elevation of Building 1880 located at **1880 Dr. Andre's Way**, by finding that the request is consistent with the Comprehensive Plan and meets criteria set forth in Chapter 8 of the Land Development Regulations.
- C. Move denial, of the of the Mural Permit (2025-017) to paint a mural (façade 6) on the west elevation of Building 1880 located at **1880 Dr. Andre's Way**, by finding that the request is inconsistent with the Comprehensive Plan and meets criteria set forth in Chapter 8 of the Land Development Regulations
- D. Postpone

Façade 9 (File No. 2025-020)

- A. Move approval, of the Mural Permit (2025-020) to paint a mural (façade 9) on the east elevation of Building 1880 located at **1880 Dr. Andre's Way**, by finding that the request is consistent with the Comprehensive Plan and meets criteria set forth in Chapter 8 of the Land Development Regulations.
- B. Move approval, as amended, of the Mural permit (2025-020) to paint a mural (façade 9) on the east elevation of Building 1880 located at **1880 Dr. Andre's Way**, by finding that the request is consistent with the Comprehensive Plan and meets criteria set forth in Chapter 8 of the Land Development Regulations.
- C. Move denial of the Mural Permit (2025-020) to paint a mural (façade 9) on the east elevation of Building 1880 located at **1880 Dr. Andre's Way** by finding that the request is inconsistent with the Comprehensive Plan and meets criteria set forth in Chapter 8 of the Land Development Regulations.
- D. Postpone



DEVELOPMENT SERVICES

BUILDING | HISTORIC PRESERVATION | PLANNING & ZONING

100 NW 1st AVENUE, DELRAY BEACH, FLORIDA 33444 | (561) 243-7040 | (561) 243-7221 (fax) | www.delraybeachfl.gov

FOR OFFICE USE ONLY
FILE #:
DATE SUBMITTED:
TOTAL PAID:

MURAL PERMIT APPLICATION

A Mural permit application must be submitted for **each mural façade or wall plain** with the following completed items:

- Required fee: \$0.50 per square foot, up to a maximum of \$500.
- Fee Due 480 SF X \$0.50 = \$240 or _____ (\$500.00 Maximum fee)
- Survey or site plan showing the wall/ building or surface location;
- Wall/ building elevation or surface depicting the following:
 - Height and width of the wall or surface;
 - Location of any doors, windows, or architectural elements; and
 - Color rendering of the proposed mural.
- Description of materials, including paint type, UV protections, etc.
- Mural maintenance plan, per LDR Section 8.5.3
- Artist's Name and Biography
- Examples of other mural installations by the artist. Attach digital files with application.

Procedure: Upon submission of a complete Mural Permit application, the Public Art Advisory Board and/or Historic Preservation Board will review and evaluate the request to determine conformity with Section 8.5.3, Murals.

CONTACT INFORMATION

Property Owner:
JMS Boynton Beach LLC

Address: 1880 Dr Andres Way Unit 1	City: Delray Beach	State: FL	Zip Code: 33445
---------------------------------------	-----------------------	--------------	--------------------

Phone: 561-594-0799	Email: smichael@banyangroupe.com
------------------------	-------------------------------------

Agent/ Applicant (if other than Property Owner):

Address:	City:	State:	Zip Code:
----------	-------	--------	-----------

Phone:	Email:
--------	--------

PROPERTY INFORMATION

Property Address:
1880 Dr Andres Way Facade 3

Property Control Number (PCN):
12-43-46-18-16-000-0020

Legal Description:
MC EWEN LUMBER SUBD LOT 2

Existing Property Use: Multi Office, Warehouse	Zoning District: MROC Mixed Res Office com.
---	--

Historic District or Individually Designated:
 Yes No District: _____

PROPOSAL

Project Name:
Andrea Design District

Is the mural already completed? Yes No

Is this request a result of a code enforcement action: Yes No Case No.:

Describe in detail the proposed artwork/ mural (please provide an attachment, if necessary):

The artwork displayed on our walls are unique spray-painted murals which have a diverse subject matter. There is subject matter, style, and medium which include unity of races, Delray Beach sunsets, important current world affairs, historic people, and abstract features. This also includes landscape, portrait, as well as abstract design. There were unique techniques and methods used to create the artwork.

PROPOSAL

JMS Boynton Beach, LLC (*Owner's Name as it appears on the recorded warranty deed, see notes below if owned by a business), the fee simple owner of the property with the following legal description (as it appears on the warranty deed; attach separate sheet if necessary):

MCEWEN LUMBER SUBD LOT 2

hereby petition to the City of Delray Beach for a Mural Permit. I certify that I have examined the application and that all statements and diagrams submitted are true and accurate to the best of my knowledge. I consent to inspections, photographing and placement of signs on the subject property by City Staff for purposes of consideration of this application and/or presentation to the approving body. Further, I understand that this application, including all attachments and fees become part of the Official Records of the City of Delray Beach, Florida, and are not returnable.

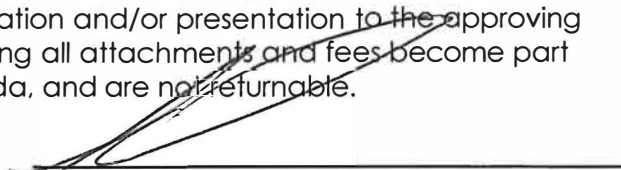

SIGNATURE - OWNER

The foregoing instrument was acknowledged before me by means of physical presence or online notarization, this 29 day of July, 2024, by Steven Michael (name of person acknowledging), who has produced _____ as identification and/or is personally known to me.



SIGNATURE - NOTARY PUBLIC

Georgia Melita

PRINT NAME - NOTARY PUBLIC

NOTARY SEAL OR STAMP



Georgia Melita
Notary Public, State of Florida
My Comm. Expires 10/11/2024
Commission No. HH 052382

My Commission Expires: 10/11/24

Building 1880 – Façade 3

Mural description: Flowers



Response:

1. The mural is 480 SF, 20' by 12' and 20' by 12'
2. Mural maintenance plan: Maintenance plan: Regular Inspections: Conduct biannual visual assessments of all murals within the city limits. Identify signs of fading, chipping, cracking, vandalism, and other damage. Document the condition of each mural, including location, artist's name, and date of creation. Immediate Repairs: Address minor issues promptly, such as touch-ups for small areas of fading or damage. Repair any vandalism or graffiti within 72 hours of identification. Annual Maintenance: Schedule annual cleaning and maintenance for all murals to remove dirt, dust, and pollutants. Use gentle cleaning methods and appropriate products to avoid damaging the mural's surface. Reapply a protective clear coat or sealant to safeguard murals against environmental factors.
3. Sign removed
4. Acknowledged
5. See response to 2
6. Biography of artist: Denny Graff, a dynamic and multi-talented graffiti artist, muralist, acrylic painter, and designer hailing from the vibrant city of Orlando, Florida. With a passion for color and a knack for transforming spaces, Denny Graff has become a prominent figure in the urban art scene. From the bustling streets of Orlando to the expansive walls of Wynwood, Denny Graff's work is a fusion of bold graffiti styles and intricate acrylic techniques. His murals are not just paintings; they are stories told through a spray-can, capturing the essence of street culture with every vibrant line and curve. Denny Graff began his artistic journey on the streets, armed with nothing but spray cans and a vision to bring art to unexpected places. His graffiti is a testament to their roots-raw, expressive, and unapologetically

bold. As he evolved, so did their medium, embracing acrylics to bring a new depth and texture to his work. In the world of design, Denny Graff is known for his unique ability to blend urban grit with contemporary aesthetics. His designs, whether for apparel, posters, or branding, are infused with the same energy and color that make street art so captivating. With each mural, Denny Graff aims to not only beautify spaces but also to inspire and provoke thought. His work is a dialogue with the community, a visual feast that encourages viewers to question, interpret, and connect. Denny Graff continues to push the boundaries of urban art, leaving a trail of awe-inspiring murals and designs in their wake. In the ever-changing landscape of street art, Denny Graff stands out as not just an artist, but as a visionary, constantly redefining what it means to create art in the urban jungle. You may see Denny Graff's work throughout Wynwood, Miami, Orlando, and Tampa.



DEVELOPMENT SERVICES

BUILDING | HISTORIC PRESERVATION | PLANNING & ZONING

100 NW 1st AVENUE, DELRAY BEACH, FLORIDA 33444 | (561) 243-7040 | (561) 243-7221 (fax) | www.delraybeachfl.gov

FOR OFFICE USE ONLY
FILE #:
DATE SUBMITTED:
TOTAL PAID:

MURAL PERMIT APPLICATION

A Mural permit application must be submitted for **each mural façade or wall plain** with the following completed items:

- Required fee: \$0.50 per square foot, up to a maximum of \$500.
- Fee Due 604 SF X \$0.50 = \$302 or _____ (\$500.00 Maximum fee)
- Survey or site plan showing the wall/ building or surface location;
- Wall/ building elevation or surface depicting the following:
 - Height and width of the wall or surface;
 - Location of any doors, windows, or architectural elements; and
 - Color rendering of the proposed mural.
- Description of materials, including paint type, UV protections, etc.
- Mural maintenance plan, per LDR Section 8.5.3
- Artist's Name and Biography
- Examples of other mural installations by the artist. Attach digital files with application.

Procedure: Upon submission of a complete Mural Permit application, the Public Art Advisory Board and/or Historic Preservation Board will review and evaluate the request to determine conformity with Section 8.5.3, Murals.

CONTACT INFORMATION

Property Owner:

JMS Boynton Beach LLC

Address: 1880 Dr Andres Way Unit 1	City: Delray Beach	State: FL	Zip Code: 33445
---------------------------------------	-----------------------	--------------	--------------------

Phone: 561-594-0799	Email: smichael@banyangroupe.com
------------------------	-------------------------------------

Agent/ Applicant (if other than Property Owner):

Address:	City:	State:	Zip Code:
----------	-------	--------	-----------

Phone:	Email:
--------	--------

PROPERTY INFORMATION

Property Address:
1880 Dr Andres Way Facade 4&5

Property Control Number (PCN):
12-43-46-18-16-000-0020

Legal Description:
MC EWEN LUMBER SUBD LOT 2

Existing Property Use: Multi Office, Warehouse	Zoning District: MROC Mixed Res Office com.
---	--

Historic District or Individually Designated:
 Yes No District: _____

PROPOSAL

Project Name:
Andrea Design District

Is the mural already completed? Yes No

Is this request a result of a code enforcement action: Yes No Case No.:

Describe in detail the proposed artwork/ mural (please provide an attachment, if necessary):
The artwork displayed on our walls are unique spray-painted murals which have a diverse subject matter. There is subject matter, style, and medium which include unity of races, Delray Beach sunsets, important current world affairs, historic people, and abstract features. This also includes landscape, portrait, as well as abstract design. There were unique techniques and methods used to create the artwork.

PROPOSAL

JMS Boynton Beach, LLC (*Owner's Name as it appears on the recorded warranty deed, see notes below if owned by a business), the fee simple owner of the property with the following legal description (as it appears on the warranty deed; attach separate sheet if necessary):

MCEWEN LUMBER SUBD LOT 2

hereby petition to the City of Delray Beach for a Mural Permit. I certify that I have examined the application and that all statements and diagrams submitted are true and accurate to the best of my knowledge. I consent to inspections, photographing and placement of signs on the subject property by City Staff for purposes of consideration of this application and/or presentation to the approving body. Further, I understand that this application, including all attachments and fees become part of the Official Records of the City of Delray Beach, Florida, and are not returnable.

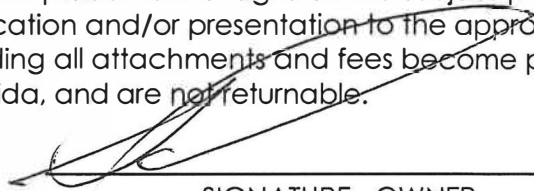

SIGNATURE - OWNER

The foregoing instrument was acknowledged before me by means of physical presence or online notarization, this 29 day of July, 2024, by Steven Michael (name of person acknowledging), who has produced _____ as identification and/or is personally known to me.



SIGNATURE - NOTARY PUBLIC

Georgia Melita

Notary Public, State of Florida
My Comm. Expires 10/11/2024
Commission No. HH 052382



NOTARY SEAL OR STAMP

Georgia Melita

PRINT NAME - NOTARY PUBLIC

My Commission Expires: 10/11/24

Building 1880 – Façade 4&5

Mural description: Cars



2. Maintenance plan: Regular Inspections: Conduct biannual visual assessments of all murals within the city limits. Identify signs of fading, chipping, cracking, vandalism, and other damage. Document the condition of each mural, including location, artist's name, and date of creation. Immediate Repairs: Address minor issues promptly, such as touch-ups for small areas of fading or damage. Repair any vandalism or graffiti within 72 hours of identification. Annual Maintenance: Schedule annual cleaning and maintenance for all murals to remove dirt, dust, and pollutants. Use gentle cleaning methods and appropriate products to avoid damaging the mural's surface. Reapply a protective clear coat or sealant to safeguard murals against environmental factors.
3. See 2.
4. Biography of the artist: Denny Graff, a dynamic and multi-talented graffiti artist, muralist, acrylic painter, and designer hailing from the vibrant city of Orlando, Florida. With a passion for color and a knack for transforming spaces, Denny Graff has become a prominent figure in the urban art scene. From the bustling streets of Orlando to the expansive walls of Wynwood, Denny Graff's work is a fusion of bold graffiti styles and intricate acrylic techniques. His murals are not just paintings; they are stories told through a spray-can, capturing the essence of street culture with every vibrant line and curve. Denny Graff began his artistic journey on the streets, armed with nothing but spray cans and a vision to bring art to unexpected places. His graffiti is a testament to their roots-raw, expressive, and unapologetically bold. As he evolved, so did their medium, embracing acrylics to bring a new depth and texture to his work. In the world of design, Denny Graff is known for his unique ability to blend urban grit with contemporary aesthetics. His designs, whether for apparel, posters, or branding, are infused with the

same energy and color that make street art so captivating. With each mural, Denny Graff aims to not only beautify spaces but also to inspire and provoke thought. His work is a dialogue with the community, a visual feast that encourages viewers to question, interpret, and connect. Denny Graff continues to push the boundaries of urban art, leaving a trail of awe-inspiring murals and designs in their wake. In the ever-changing landscape of street art, Denny Graff stands out as not just an artist, but as a visionary, constantly redefining what it means to create art in the urban jungle. You may see Denny Graff's work throughout Wynwood, Miami, Orlando, and Tampa.



DEVELOPMENT SERVICES

BUILDING | HISTORIC PRESERVATION | PLANNING & ZONING

100 NW 1ST AVENUE, DELRAY BEACH, FLORIDA 33444 | (561) 243-7040 | (561) 243-7221 (fax) | www.delraybeachfl.gov

FOR OFFICE USE ONLY
FILE #:
DATE SUBMITTED:
TOTAL PAID:

MURAL PERMIT APPLICATION

A Mural permit application must be submitted for **each mural façade or wall plain** with the following completed items:

- Required fee: \$0.50 per square foot, up to a maximum of \$500.
- Fee Due 240 SF X \$0.50 = \$120 or _____ (\$500.00 Maximum fee)
- Survey or site plan showing the wall/ building or surface location;
- Wall/ building elevation or surface depicting the following:
 - Height and width of the wall or surface;
 - Location of any doors, windows, or architectural elements; and
 - Color rendering of the proposed mural.
- Description of materials, including paint type, UV protections, etc.
- Mural maintenance plan, per LDR Section 8.5.3
- Artist's Name and Biography
- Examples of other mural installations by the artist. Attach digital files with application.

Procedure: Upon submission of a complete Mural Permit application, the Public Art Advisory Board and/or Historic Preservation Board will review and evaluate the request to determine conformity with Section 8.5.3, Murals.

CONTACT INFORMATION

Property Owner: JMS Boynton Beach LLC			
Address: 1880 Dr Andres Way Unit 1	City: Delray Beach	State: FL	Zip Code: 33445
Phone: 561-594-0799	Email: smichael@banyangroupe.com		
Agent/ Applicant (if other than Property Owner):			
Address:	City:	State:	Zip Code:
Phone:	Email:		

PROPERTY INFORMATION

Property Address: 1880 Dr Andres Way Facade 8	
Property Control Number (PCN): 12-43-46-18-16-000-0020	
Legal Description: MC EWEN LUMBER SUBD LOT 2	
Existing Property Use: Multi Office, Warehouse	Zoning District: MROC Mixed Res Office com.
Historic District or Individually Designated: <input type="checkbox"/> Yes <input checked="" type="checkbox"/> No District: _____	

PROPOSAL

Project Name:
Andrea Design District

Is the mural already completed? Yes No

Is this request a result of a code enforcement action: Yes No Case No.:

Describe in detail the proposed artwork/ mural (please provide an attachment, if necessary):
The artwork displayed on our walls are unique spray-painted murals which have a diverse subject matter. There is subject matter, style, and medium which include unity of races, Delray Beach sunsets, important current world affairs, historic people, and abstract features. This also includes landscape, portrait, as well as abstract design. There were unique techniques and methods used to create the artwork.

PROPOSAL

JMS Boynton Beach, LLC (*Owner's Name as it appears on the recorded warranty deed, see notes below if owned by a business), the fee simple owner of the property with the following legal description (as it appears on the warranty deed; attach separate sheet if necessary):

MCEWEN LUMBER SUBD LOT 2

hereby petition to the City of Delray Beach for a Mural Permit. I certify that I have examined the application and that all statements and diagrams submitted are true and accurate to the best of my knowledge. I consent to inspections, photographing and placement of signs on the subject property by City Staff for purposes of consideration of this application and/or presentation to the approving body. Further, I understand that this application, including all attachments and fees become part of the Official Records of the City of Delray Beach, Florida, and are not returnable.

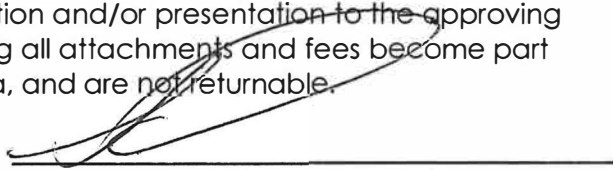

SIGNATURE - OWNER

The foregoing instrument was acknowledged before me by means of physical presence or online notarization, this 29 day of July, 2024, by Steven Michael (name of person acknowledging), who has produced _____ as identification and/or is personally known to me.

Georgia Melita
SIGNATURE - NOTARY PUBLIC

NOTARY SEAL OR STAMP



Georgia Melita
Notary Public, State of Florida
My Comm. Expires 10/11/2024
Commission No. HH 052382

Georgia Melita
PRINT NAME - NOTARY PUBLIC

My Commission Expires: 10/11/24

Building 1880 – Façade 8

Mural description: Formulas



Response:

1. The mural is 240 SF, 20' by 12'

2. Maintenance plan:
Regular Inspections: Conduct biannual visual assessments of all murals within the city limits. Identify signs of fading, chipping, cracking, vandalism, and other damage. Document the condition of each mural, including location, artist's name, and date of creation.
Immediate Repairs: Address minor issues promptly, such as touch-ups for small areas of fading or damage. Repair any vandalism or graffiti within 72 hours of identification.
Annual Maintenance: Schedule annual cleaning and maintenance for all murals to remove dirt, dust, and pollutants. Use gentle cleaning methods and appropriate products to avoid damaging the mural's surface. Reapply a protective clear coat or sealant to safeguard murals against

environmental factors.

3. See 2.
4. Biography of the artist: Denny Graff, a dynamic and multi-talented graffiti artist, muralist, acrylic painter, and designer hailing from the vibrant city of Orlando, Florida. With a passion for color and a knack for transforming spaces, Denny Graff has become a prominent figure in the urban art scene. From the bustling streets of Orlando to the expansive walls of Wynwood, Denny Graff's work is a fusion of bold graffiti styles and intricate acrylic techniques. His murals are not just paintings; they are stories told through a spray-can, capturing the essence of street culture with every vibrant line and curve. Denny Graff began his artistic journey on the streets, armed with nothing but spray cans and a vision to bring art to unexpected places. His graffiti is a testament to their roots-raw, expressive, and unapologetically

bold. As he evolved, so did their medium, embracing acrylics to bring a new depth and texture to his work. In the world of design, Denny Graff is known for his unique ability to blend urban grit with contemporary aesthetics. His designs, whether for apparel, posters, or branding, are infused with the same energy and color that make street art so captivating. With each mural, Denny Graff aims to not only beautify spaces but also to inspire and provoke thought. His work is a dialogue with the community, a visual feast that encourages viewers to question, interpret, and connect. Denny Graff continues to push the boundaries of urban art, leaving a trail of awe-inspiring murals and designs in their wake. In the ever-changing landscape of street art, Denny Graff stands out as not just an artist, but as a visionary, constantly redefining what it means to create art in the urban jungle. You may see Denny Graff's work throughout Wynwood, Miami, Orlando, and Tampa.





DEVELOPMENT SERVICES

BUILDING | HISTORIC PRESERVATION | PLANNING & ZONING

100 NW 1st AVENUE, DELRAY BEACH, FLORIDA 33444 | (561) 243-7040 | (561) 243-7221 (fax) | www.delraybeachfl.gov

FOR OFFICE USE ONLY
FILE #:
DATE SUBMITTED:
TOTAL PAID:

MURAL PERMIT APPLICATION

A Mural permit application must be submitted for **each mural façade or wall plain** with the following completed items:

- Required fee: \$0.50 per square foot, up to a maximum of \$500.
- Fee Due 360 SF X \$0.50 = 180 or _____ (\$500.00 Maximum fee)
- Survey or site plan showing the wall/ building or surface location;
- Wall/ building elevation or surface depicting the following:
 - Height and width of the wall or surface;
 - Location of any doors, windows, or architectural elements; and
 - Color rendering of the proposed mural.
- Description of materials, including paint type, UV protections, etc.
- Mural maintenance plan, per LDR Section 8.5.3
- Artist's Name and Biography
- Examples of other mural installations by the artist. Attach digital files with application.

Procedure: Upon submission of a complete Mural Permit application, the Public Art Advisory Board and/or Historic Preservation Board will review and evaluate the request to determine conformity with Section 8.5.3, Murals.

CONTACT INFORMATION

Property Owner:
JMS Boynton Beach LLC

Address: 1880 Dr Andres Way Unit 1	City: Delray Beach	State: FL	Zip Code: 33445
---------------------------------------	-----------------------	--------------	--------------------

Phone: 561 594 0799	Email: smichael@banyangroupe.com
------------------------	-------------------------------------

Agent/ Applicant (if other than Property Owner):

Address:	City:	State:	Zip Code:
----------	-------	--------	-----------

Phone:	Email:
--------	--------

PROPERTY INFORMATION

Property Address:
1880 Dr Andres Way Facade 2

Property Control Number (PCN):
12-43-46-18-16-000-0020

Legal Description:
MC EWEN LUMBER SUBD LOT 2

Existing Property Use: Multi Office, Warehouse	Zoning District: MROC Mixed Res Office com.
---	--

Historic District or Individually Designated:

Yes No District: _____

PROPOSAL

Project Name:
Andrea design District

Is the mural already completed? Yes No

Is this request a result of a code enforcement action: Yes No Case No.:

Describe in detail the proposed artwork/ mural (please provide an attachment, if necessary):
The artwork displayed on our walls are unique spray-painted murals which have a diverse subject matter. There is subject matter, style, and medium which include unity of races, Delray Beach sunsets, important current world affairs, historic people, and abstract features. This also includes landscape, portrait, as well as abstract design. There were unique techniques and methods used to create the artwork.

PROPOSAL

JMS Boynton Beach, LLC (*Owner's Name as it appears on the recorded warranty deed, see notes below if owned by a business), the fee simple owner of the property with the following legal description (as it appears on the warranty deed; attach separate sheet if necessary):

MCEWEN LUMBER SUBD LOT 2

hereby petition to the City of Delray Beach for a Mural Permit. I certify that I have examined the application and that all statements and diagrams submitted are true and accurate to the best of my knowledge. I consent to inspections, photographing and placement of signs on the subject property by City Staff for purposes of consideration of this application and/or presentation to the approving body. Further, I understand that this application, including all attachments and fees become part of the Official Records of the City of Delray Beach, Florida, and are not returnable.

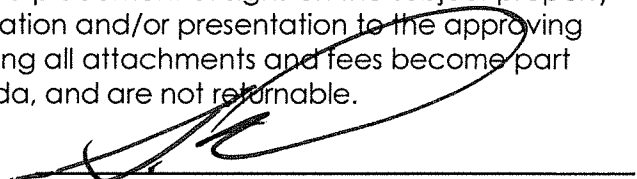

SIGNATURE - OWNER

The foregoing instrument was acknowledged before me by means of physical presence or online notarization, this 28 day of February, 2025, by Steven Michael (name of person acknowledging), who has produced personally known as identification and/or is personally known to me.

Georgia Melita
SIGNATURE - NOTARY PUBLIC

Georgia Melita
PRINT NAME - NOTARY PUBLIC

NOTARY SEAL OR STAMP

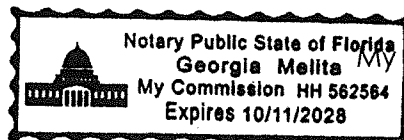

Commission Expires: 10/11/28

Front



Facade 2
360 sq.ft.
30'wide by 12' tall

Building 1880

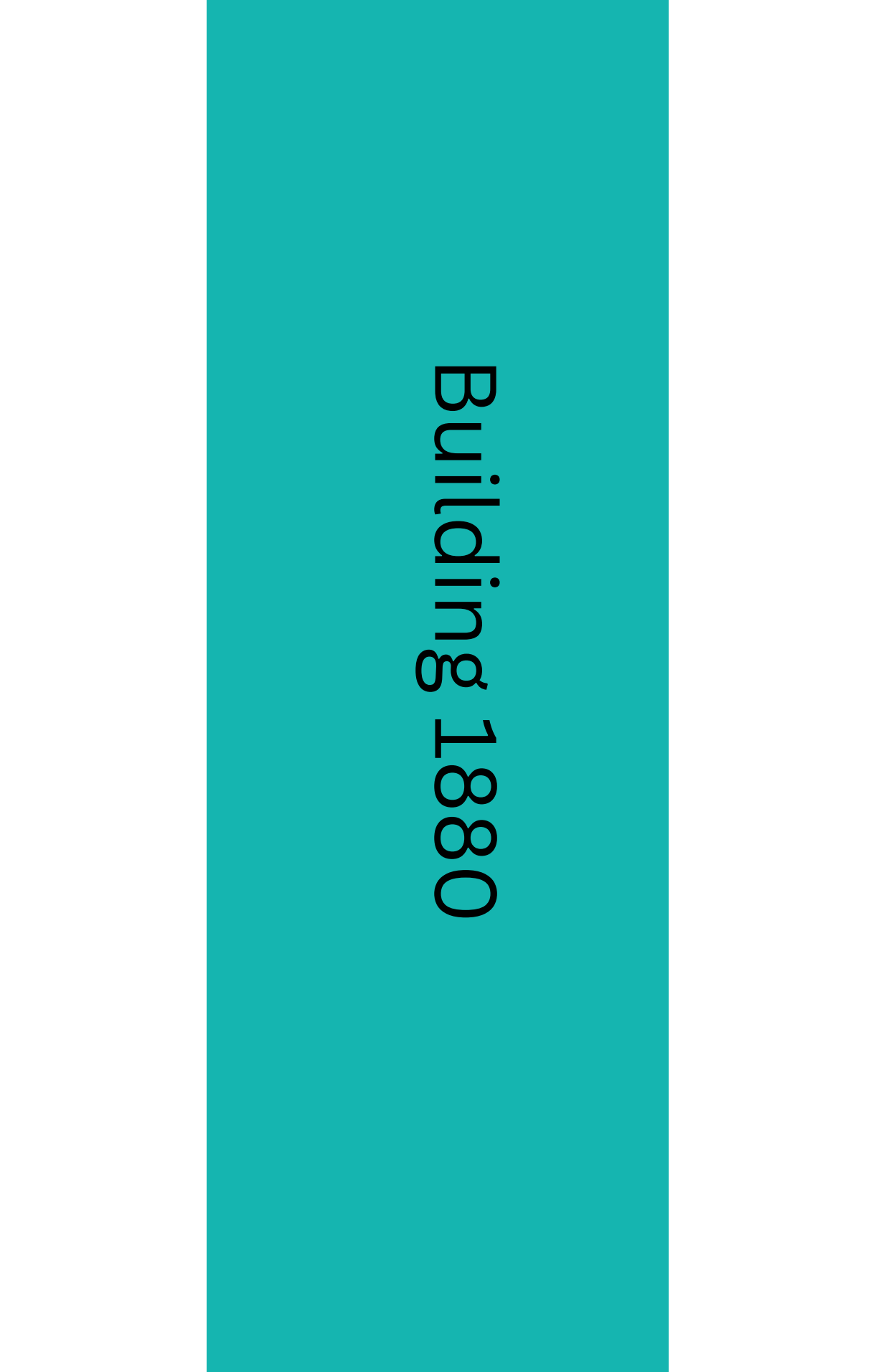

Back

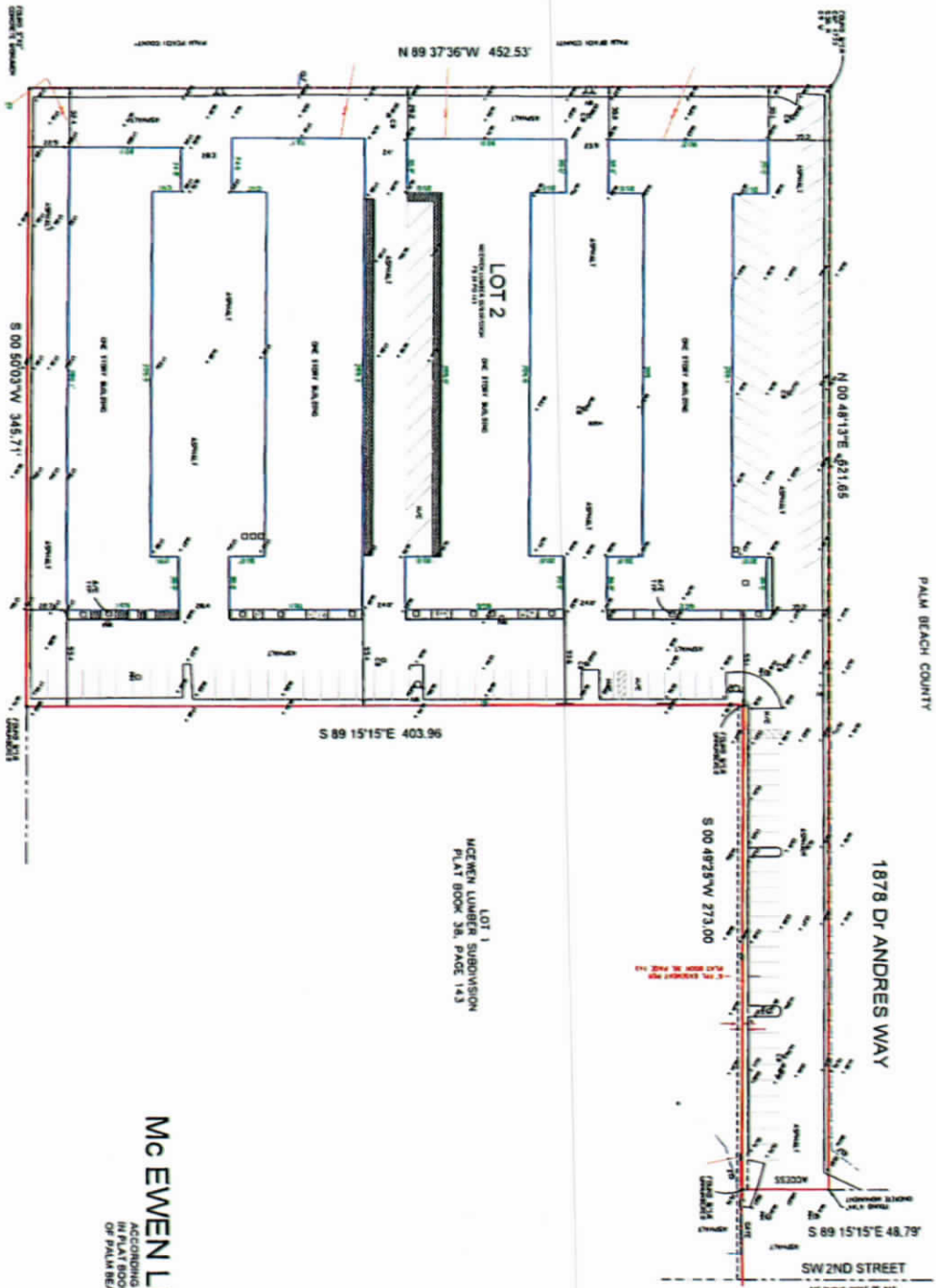

LOT 2
McEWEN LUMBER SUBDIVISION
 ACCORDING TO THE PLAT THEREOF AS RECORDED
 IN PLAT BOOK 38 PAGE 143 OF THE PUBLIC RECORDS
 OF PALM BEACH COUNTY, FLORIDA



Robert Ferguson
LAND SURVEYING
 1000 S.W. 11th St., Suite 200
 West Palm Beach, FL 33411-3111
 Phone: 561-833-1111
 Fax: 561-833-1112
 Email: rf@robertferguson.com
 Website: www.robertferguson.com

I, ROBERT FERGUSON, Surveyor No. 12345, do hereby certify that the above is a true and correct copy of the original plat as recorded in the public records of Palm Beach County, Florida.

DATE: 11/15/2023
 BY: ROBERT FERGUSON
 TITLE: SURVEYOR

Building 1880 - Façade 2

Mural description: Spiral Dream



Response:

1. The mural is 360 SF (30' wide by 12' tall) and 100% of the façade. The façade does not include any windows, doors or any architectural elements.

Materials used: Montana colors “Hardcore” spray paint. Physical properties of the paint:

Propellant: Butane / Propane / Mix.

Shine: 60-80% gloss, <20% matt. Heat resistance of paint: 100 degrees Celsius.

UV protection: “Mural Shield”. MuralShield is designed for the protection and conservation of murals. It offers UV protection, consolidation, and weatherproofing.

2. Maintenance plan:

Regular Inspections: Conduct biannual visual assessments of all murals within the city limits. Identify signs of fading, chipping, cracking, vandalism, and other damage. Document the condition of each mural, including location, artist's name, and date of creation. Immediate

Repairs: Address minor issues promptly, such as touch-ups for small

areas of fading or damage. Repair any vandalism or graffiti within 72 hours of identification. Annual Maintenance: Schedule annual cleaning and maintenance for all murals to remove dirt, dust, and pollutants. Use gentle cleaning methods and appropriate products to avoid damaging the mural's surface. Reapply a protective clear coat or sealant to safeguard murals against environmental factors.

3. Biography of artist: Denny Graff, a dynamic and multi-talented graffiti artist, muralist, acrylic painter, and designer hailing from the vibrant city of Orlando, Florida. With a passion for color and a knack for transforming spaces, Denny Graff has become a prominent figure in the urban art scene. From the bustling streets of Orlando to the expansive walls of Wynwood, Denny Graff's work is a fusion of bold graffiti styles and intricate acrylic techniques. His murals are not just paintings; they are stories told through a spray-can, capturing the essence of street culture with every vibrant line and curve. Denny Graff began his artistic journey on the streets, armed with nothing but spray cans and a vision to bring art to unexpected places. His graffiti is a testament to their roots-raw, expressive, and unapologetically bold. As he evolved, so did their medium, embracing acrylics to bring a new depth and texture to his work. In the world of design, Denny Graff is known for his unique ability to blend urban grit with contemporary aesthetics. His designs, whether for apparel, posters, or branding, are infused with the same energy and color that make street art so captivating. With each mural, Denny Graff aims to not only beautify spaces but also to inspire and provoke thought. His work is a dialogue with the community, a visual feast that encourages viewers to question, interpret, and connect. Denny Graff continues to push the boundaries of urban art, leaving a trail of awe-inspiring murals and designs in their wake. In the ever-changing landscape of street art, Denny Graff stands out as not just an artist, but as a visionary, constantly redefining what it means to create art in the urban jungle. You may see Denny Graff's work throughout Wynwood, Miami, Orlando, and Tampa.



Denny Graff

Denny Graff stands out as not just an artist, but as a visionary, constantly redefining what it means to create art in the urban jungle. You may see Denny Graff's work throughout Wynwood, Miami, Orlando, and Tampa.

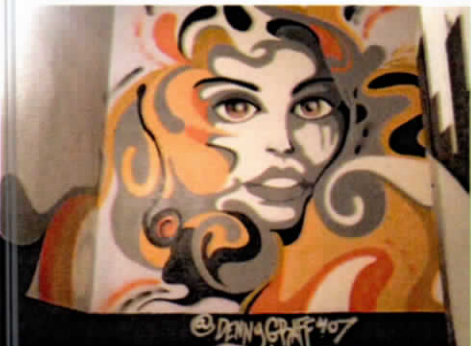
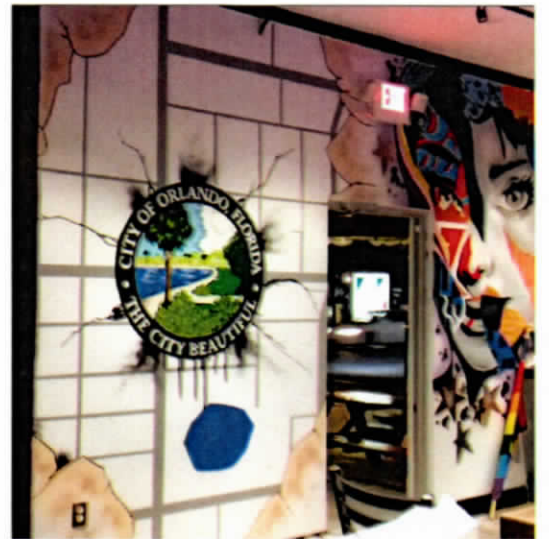



1880
DESIGN
DISTRICT

STOP



[Department of State](#) / [Division of Corporations](#) / [Search Records](#) / [Search by Entity Name](#) /

Detail by Entity Name

Florida Limited Liability Company
JMS BOYNTON BEACH LLC

Filing Information

Document Number L13000039242
FEI/EIN Number 46-2576836
Date Filed 03/14/2013
State FL
Status ACTIVE

Principal Address

4868 W. Dempster St.
SUITE 2E
Skokie, IL 60077

Changed: 01/09/2014

Mailing Address

4868 W. Dempster St. 2E
skokie, IL 60077

Changed: 11/08/2013

Registered Agent Name & Address

DADE COUNTY CORPORATE AGENTS INC.
20295 N.E. 29th Place
SUITE 200
AVENTURA, FL 33180

Address Changed: 01/09/2017

Authorized Person(s) Detail

Name & Address

Title Manager

Michael, Mark B

4868 W. Dempster St.
Skokie, IL 60077

Title Manager

Michael, Steven A.
20 S Swinton Avenue
Delray Beach, FL 33444

Annual Reports

Report Year	Filed Date
2023	01/23/2023
2024	02/06/2024
2025	02/05/2025

Document Images

02/05/2025 -- ANNUAL REPORT	View image in PDF format
02/06/2024 -- ANNUAL REPORT	View image in PDF format
01/23/2023 -- ANNUAL REPORT	View image in PDF format
01/24/2022 -- ANNUAL REPORT	View image in PDF format
01/29/2021 -- ANNUAL REPORT	View image in PDF format
01/21/2020 -- ANNUAL REPORT	View image in PDF format
03/28/2019 -- AMENDED ANNUAL REPORT	View image in PDF format
02/06/2019 -- ANNUAL REPORT	View image in PDF format
01/12/2018 -- ANNUAL REPORT	View image in PDF format
01/09/2017 -- ANNUAL REPORT	View image in PDF format
03/02/2016 -- ANNUAL REPORT	View image in PDF format
01/07/2015 -- ANNUAL REPORT	View image in PDF format
01/09/2014 -- ANNUAL REPORT	View image in PDF format
03/14/2013 -- Florida Limited Liability	View image in PDF format

2025 FLORIDA LIMITED LIABILITY COMPANY ANNUAL REPORT

DOCUMENT# L13000039242

Entity Name: JMS BOYNTON BEACH LLC

Current Principal Place of Business:

4868 W. DEMPSTER ST.
SUITE 2E
SKOKIE, IL 60077

Current Mailing Address:

4868 W. DEMPSTER ST. 2E
SKOKIE, IL 60077 US

FEI Number: 46-2576836

Certificate of Status Desired: No

Name and Address of Current Registered Agent:

DADE COUNTY CORPORATE AGENTS INC.
20295 N.E. 29TH PLACE
SUITE 200
AVENTURA, FL 33180 US

The above named entity submits this statement for the purpose of changing its registered office or registered agent, or both, in the State of Florida.

SIGNATURE:

Electronic Signature of Registered Agent

Date

Authorized Person(s) Detail :

Title MANAGER
Name MICHAEL, MARK B
Address 4868 W. DEMPSTER ST.
City-State-Zip: SKOKIE IL 60077

Title MANAGER
Name MICHAEL, STEVEN A.
Address 20 S SWINTON AVENUE
City-State-Zip: DELRAY BEACH FL 33444

I hereby certify that the information indicated on this report or supplemental report is true and accurate and that my electronic signature shall have the same legal effect as if made under oath; that I am a managing member or manager of the limited liability company or the receiver or trustee empowered to execute this report as required by Chapter 605, Florida Statutes; and that my name appears above, or on an attachment with all other like empowered.

SIGNATURE: MARK MICHAEL

MANAGER

02/05/2025

Electronic Signature of Signing Authorized Person(s) Detail

Date