



DEVELOPMENT SERVICES

BUILDING | HISTORIC PRESERVATION | PLANNING & ZONING

PUBLIC ARTS ADVISORY BOARD STAFF REPORT

1880 Dr. Andre's Way

Meeting	File No.	Application Type
February 25, 2025	2025-015 (Bldg. 1880 Façade 1) 2025-016 (Bldg. 1880 Façade 3) 2025-017 (Bldg. 1880 Façade 6) 2025-018 (Bldg. 1880 Façade 7) 2025-019 (Bldg. 1880 Façade 8)	2025-020 (Bldg. 1880 Façade 9) 2025-021 (Bldg. 1880 Façade 10A) 2025-022 (Bldg. 1880 Façade 10 B) 2025-023 (Bldg. 1880 Façade 11)
Property Owner	Applicant /Agent	
JMS Boynton Beach	Steven Michael	

Request

Consideration of the installation of 9 murals on Building 1880 located at 1880 Dr. Andre's Way.

General Data

Location: 1880 Dr. Andre's Way

PCN: 12-43-46-18-16-000-0020

Property Size: 3.9 acres

Land Use Designation: Congress Avenue Mixed Use (CMU)

Zoning District: Mixed Residential Office Commercial (MROC)

Adjacent Zoning:

- North, South, and West – MROC
- East: Conservation District (CD) and Florida Department of Transportation (Railroad)

Existing Use: Mixed Use Commercial, Retail, Warehouse and Light Industrial

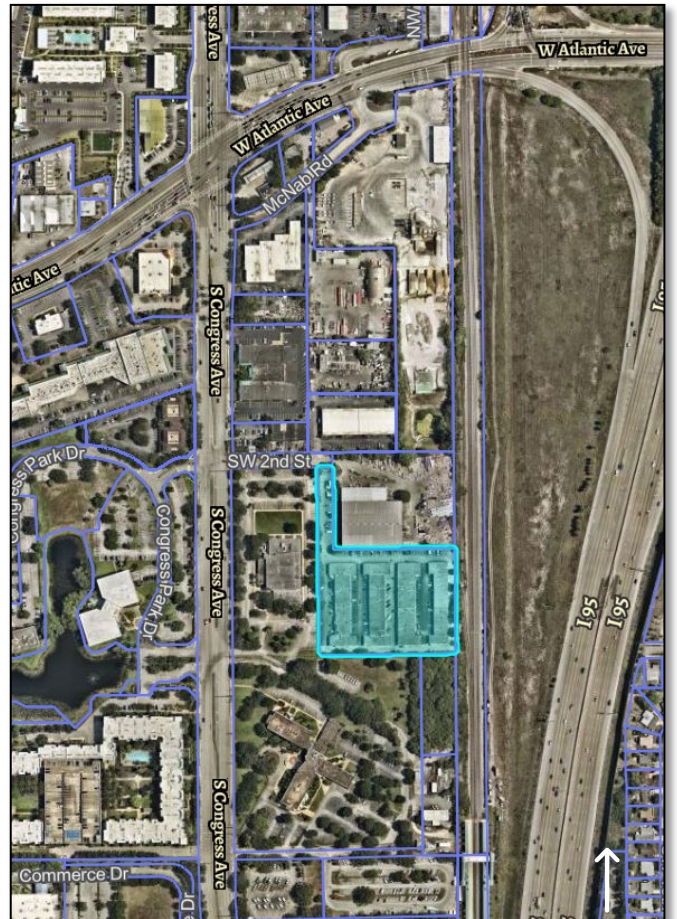

Background

The subject property is located directly west of I-95 and the FEC Railway, south of Atlantic Avenue on the east side of South Congress Avenue. The site is approximately 286 feet from S. Congress Avenue, beyond the County's Administrative Complex that is accessible by SW 2nd Street unto Dr. Andre's Way; a private access into the subject property. The 3.91-acre site, also known as "Andre's Design District" is located within the Mixed Residential Office and Commercial (MROC) zoning district and features four warehouse buildings, each with its own address, and associated parking providing 176 parking spaces. A summary of the development history is outlined below:

1979: The City Commission approved the final plat for a two-lot subdivision. Lot 1 received a Conditional Use for the McEwen Lumber Company. Additionally, a site plan was approved for the Store-All Warehouse Center Industrial Park to develop a four-building office/warehouse complex (Building A–D) with a total gross floor area of 65,075 square feet. Construction of these buildings occurred between 1981 and 1985.

1984: A site plan modification was approved to reduce the footprint of Building D (1874) from 18,000 square feet to 12,935 square feet. All four buildings are single-story structures.

1990: As part of a Citywide rezoning initiative, the property's zoning designation was changed from Light Industrial (LI) to Mixed Industrial and Commercial (MIC).

1997: The City Commission granted a Conditional Use to convert four bays, totaling 1,500 square feet located at the northeast corner of the site, to accommodate a stone cutting facility. Furthermore, the City Commission approved an amendment to the MIC zoning district regulations, reclassifying automobile paint, body, and repair shop from a Permitted use to a Conditional Use.

1998: An additional 9,785 square feet received Conditional Use approval for the establishment of automobile paint, body, and repair shops.

2004: The Public Art Advisory Board was established via Ordinance No. 77-04 with the purpose of advising and making recommendations to the City Commission on public art policy.

2007: City Commission passed Ordinance No. 5-07 to rezone the property from MIC to MROC zoning district.

2019: The current property owner acquired the four buildings with a vision to transform them into Delray's next hub for local businesses, galleries and restaurants which are permitted uses within the MROC zoning district. To attract the public to the "off the beaten path" unique mix of businesses known as "The Andre Design District", a series of murals were commissioned.

However, these murals were installed without the required mural permit approvals, in violation of the Land Development Regulations (LDR).

2022: The site became a subject to code enforcement action due to the unauthorized painting of the murals, without approval through the required mural permit process. At that time, mural installations were not permitted within the MROC zoning district.

In response, the City Commission adopted Ordinance No. 22-20, which expanded the zoning districts allowed for mural installations to include MROC, streamlining the approval process. Currently, there are 36 murals adorning the buildings, with each mural either directly associated with an individual tenant space or located on the exterior walls of the multi-bay warehouse.



It should be noted that the Code Enforcement case related to these murals remains active until all murals receive formal approval through the Public Arts Advisory Board (PAAB). Mural permit applications have been duly submitted for each building, and the murals are now scheduled for review and final action by the Board.

April 23, 2024: At the PAAB meeting, the board approved the first three murals for façades 1 and 4 on Building 1876 and façade 4 on Building 1874. The review of murals on Façade 2 of Building 1876 was postponed to a later meeting date to allow for concurrent review of all proposed murals on the same façade. This should enable the Board to determine if the murals represent a consistent theme or image.

October 29, 2024: The PAAB approved five murals on façade 2 of Building 1876.

November 26, 2024: The 13 murals located on Building 1878 were scheduled at the PAAB meeting but were postponed to the January 28, 2025 meeting.

January 28, 2025: The 13 murals located on Building 1878 were scheduled at the PAAB meeting and no action was taken due to the applicant absence.

February 13, 2025: The 13 murals remain under review by Code Enforcement Board.

February 25, 2025: The following 9 murals located on Building 1880 are scheduled for review by the PAAB.

Description of Request

LDR Section 2.1.8(E)(5), Duties, powers, and responsibilities. Board Actions

The following duties, powers, and responsibilities shall be carried out by the Public Art Advisory Board: The Board shall take action on all requests for the installation of murals on property not located within a historic district or on any individually designated site listed on the Local Register of Historic Places.

LDR Section 2.1.8(F), Final Actions.

All decisions may be appealed to the City Commission, pursuant to the procedures of [Chapter 2](#).

The request is to allow 9 existing murals on building 1880 located at 1880 Dr. Andre's Way. A total of 9 mural permit applications have been submitted, however, a total of 10 murals are existing on the façades of building 1880. On facade 2 is an existing mural, however no permit application was submitted within this request.

Pursuant to **LDR Section 8.5.3(C)(3)**, each **façade** is limited to **one** mural and may continue across a contiguous wall provided that the image or theme is consistent throughout. Each façade or surface included in the mural shall require a separate mural permit application.

Building 1880 has a total of **12 façades**. A "façade" is considered the exterior surface or face of a building. Therefore, each flat surface of the exterior wall of the building is considered a distinct façade.

Façade 4, no murals exist; however, the walls are painted in a black color without prior approval through the required color-change approval process. A subsequent permit application request was submitted by a tenant bay to propose a mural on façade 4.

Façade 5 and a portion of façade 4, these surfaces were painted in pink without obtaining the required color-change approval.

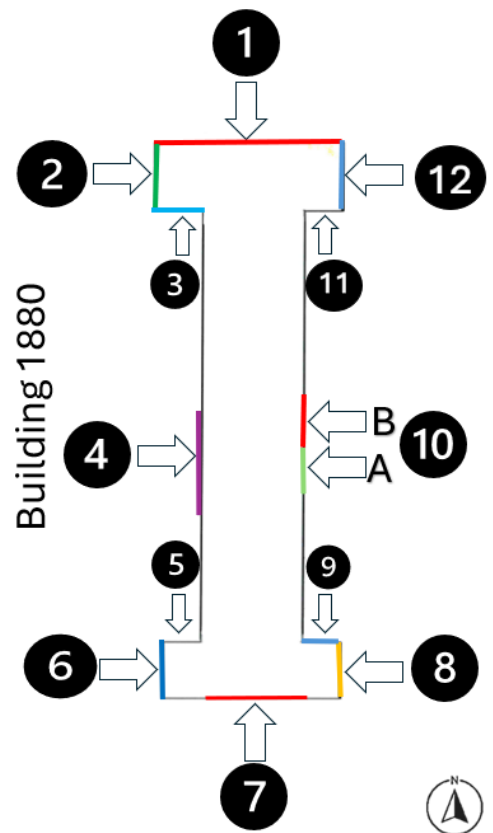

Façade 10, includes 2 murals (A & B), each with its own mural permit application. The Board must determine whether the existing murals on façade 10 of building 1880 form a single, consistent image or theme to be considered one mural on one façade.

Pursuant to **LDR Section 8.5.2(A)**, the nine (9) criteria shall be utilized and a positive finding must be made for the Board to approve the requested mural applications, whether located on private or public property.

Building 1880 Façade 1 (File No. 2025-015)



Dimensions: 5 feet high by 90 feet wide (450 square feet)

The mural features a mix of abstract patterns, geometric motifs, and a tie-dye spiral, using a bold color palette of blue, pink, purple, red, and yellow. The design is fragmented by black diagonal lines, creating a patchwork effect that visually separates the various elements. While the intent may be to introduce vibrancy, the lack of thematic cohesion results in a disjointed composition that does not contribute to a unified artistic statement.

While the mural complies with Appendix A of the LDRs, meeting the definition of public art, its execution and placement raise concerns. The upper-band location isolates the artwork from pedestrian interaction, limiting its effectiveness in enhancing the site's public-facing aesthetic. Additionally, the varying artistic styles within the mural create a fragmented appearance, lacking a clear focal point or narrative cohesion.

While the mural complies with LDR Section 8.5.3(C) regarding coverage, placement, and absence of commercial messaging, its visual impact and thematic execution remain questionable. The composition appears more decorative than conceptually driven, raising the issue of whether it effectively serves the purpose of enhancing public art within the district.

Building 1880 Façade 2 (no mural permit application submitted)

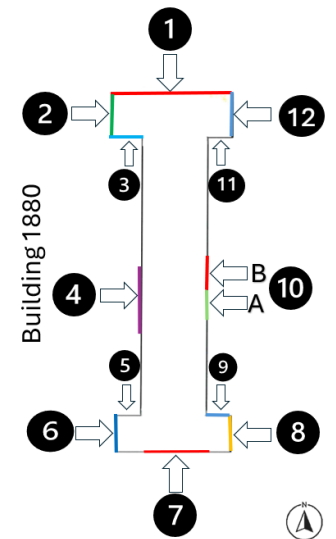

Dimensions: 12 feet high by 30 feet wide (360 square feet)
Coverage: 100% of the façade

The existing mural is located on Façade 2 on the west elevation of Building 1880. No mural permit application was submitted.

Building 1880 Façade 3 (File No. 2025-016)

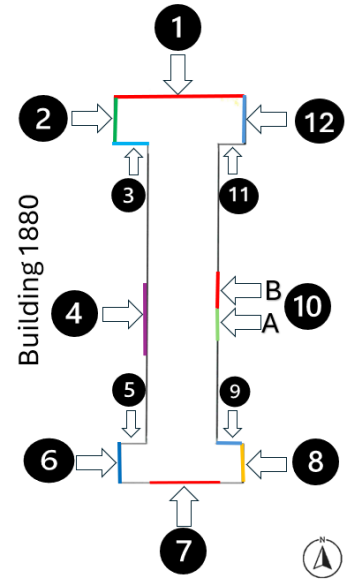

Dimensions: 12 feet high by 20 feet wide (240 square feet)
Coverage: 100% of the façade
Text Size: 9 feet by 2 feet (18 square feet) or 7.5%
Regulation Limit: 5% or 12 sq ft

The mural on Façade 3 spans 12 feet high by 20 feet wide (240 sq. ft.), covering 100% of the west elevation of Building 1880. It features large pink floral motifs set against a solid black background, with the text “Andre Design District” prominently displayed in bold pink uppercase letters. The mural is centered around an entrance door, incorporating a minimalistic floral arrangement that extends to the adjacent wall. The use of soft gradients and outlined shading in the flowers provides a sense of depth and movement, contrasting with the stark black background.



While the mural meets the general definition of public art per Appendix A of the LDRs, its integration with commercial messaging raises concerns regarding compliance with **LDR Section 8.5.3(C)(4)**, *the mural shall be predominantly pictorial, with text limited to no more than 5 percent of the proposed mural size*, except for text used to create the graphic. The “Andre Design District” text functions as identification signage rather than an artistic component, exceeding the 5% text limit established for murals. According to LDR Section 4.6.7, text within murals that serves a commercial or branding function is classified as a wall sign, requiring a separate sign permit. In this case, the mural blurs the line between artistic expression and business advertising, making it non-compliant with the mural regulations without a sign waiver.

From a design perspective, the composition is visually simplistic, relying heavily on repetitive floral imagery without a strong narrative or thematic depth. The black background, while effective in emphasizing the pink elements, creates a stark, unfinished aesthetic, especially around architectural elements like the doorway and adjacent window. The placement of the mural does not fully utilize the façade’s spatial potential, leaving significant portions of the surface **

unadorned and contributing to a sense of incompleteness. The floral imagery, while decorative, lacks the distinctive artistic character or conceptual intent seen in more immersive public art installations.

Additionally, the condition of the mural raises concerns about long-term maintenance. The black painted façade appears to have fading and uneven wear, which may accelerate deterioration of both the background and floral elements. The proximity to an entryway also increases the likelihood of scuffing, dirt accumulation, and weathering, particularly around the door and lower portions of the mural. Without clear maintenance commitments, the artwork risks degrading quickly, impacting its overall effectiveness as a public art feature.

While the mural partially meets LDR requirements for coverage, placement, and façade integration, its commercial branding, lack of thematic depth, and maintenance concerns present significant compliance issues. The use of text exceeds allowable limits, making it functionally a sign rather than a mural, and the overall artistic execution lacks narrative cohesion or transformative impact. This raises the question of whether the mural genuinely enhances the district’s creative vision or simply serves as a stylized branding tool for the development.

Building 1880 Façade 6 (File No. 2025-017)

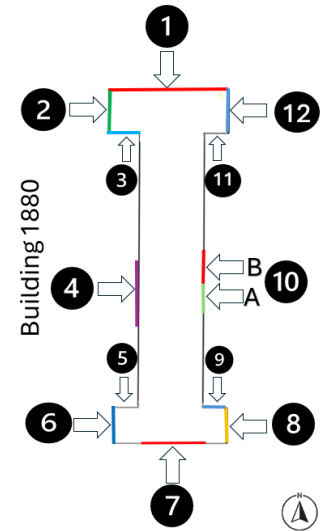

Dimensions: 12 feet high by 30 feet wide (600 square feet)
Coverage: 100% of the façade

The mural on Façade 6 spans 12 feet high by 50 feet wide (600 square feet), covering 100% of the west elevation of Building 1880. It features a purple Chevrolet Impala in motion, set against a beach-inspired background with mechanical and automotive imagery. The mural includes a large transmission illustration, multiple automotive brand logos, and industrial gear motifs, creating a dynamic yet visually fragmented composition. Above the artwork, a wall-mounted sign reading "Performance Transmission" is prominently displayed.

The Performance Transmission sign is non-conforming and lacks a permit, making it a violation of the sign code under **LDR Section 4.6.7(B)**, *it shall be unlawful for any persons to post, display, change, or erect a nonexempt sign or a sign structure, that requires a permit, without first having obtained a permit therefor. Signs or sign structures erected without a valid permit shall be deemed in violation and it shall be mandatory to obtain a permit, based on this Section, or else remove the sign or sign structure.* The MROC zoning district only allows wall signs if they face a dedicated street or I-95. Since this sign does not meet either requirement, it is not permitted and must be removed. Furthermore, it does not qualify as a building sign under the code since it functions as a commercial advertisement for the automobile repair shop rather than an architectural element.

In addition to the signage violation, the mural fails to comply with the definition of a mural under Appendix A of the LDRs, which defines a mural as *"an original, one-of-a-kind unique mosaic, painting, or graphic art or combination thereof (including collage effects) that is professionally applied to aesthetically enhance the exterior of a building or accessory structure such as a dumpster enclosure, fence, or site wall, that does not contain any brand name, product name, letters of the alphabet spelling or abbreviating the name of any product, company, profession, or business, or any logo, trademark, trade name, or other commercial message."* The inclusion of automotive brand logos such as Chevrolet, Honda, Ford, Audi, and Dodge constitutes a direct violation of this definition, as murals are strictly prohibited from incorporating brand names, logos, trademarks, or commercial messaging.

According to the United States Patent and Trademark Office (USPTO), the automotive brand logos displayed on the right side of the mural are all registered trademarks. As a result, these logos must be removed from the mural as a condition of approval to ensure compliance with LDR mural regulations. Their inclusion raises concerns regarding the blurred boundary between public art and business advertising, undermining the intent of the mural ordinance.

From an artistic standpoint, the mural demonstrates technical skill, particularly in shading, reflections, and depth. However, its composition is cluttered, with competing elements—beach scenery, mechanical components, and corporate branding—lacking thematic cohesion. The coexistence of realistic and abstract styles further contributes to visual disarray, making the mural appear

more promotional than expressive. The use of bright yellow, pink, and blue hues in the background creates a chaotic visual effect, which detracts from the overall quality of the piece.

The placement of the mural also presents challenges. The non-conforming sign disrupts the visual flow of the artwork, functioning more like a billboard than an integrated artistic element. The dark blue background of the sign contrasts awkwardly with the sky, creating an unintended separation that breaks the continuity of the design. Additionally, the low positioning of the artwork near the pavement makes it susceptible to wear, fading, and potential vandalism over time. The blue cloud-like outline surrounding the sign diminishes the mural's aesthetic integrity, further weakening its effectiveness as a cohesive public art installation.

Building 1880 Façade 7 (File No. 2025-018)



Dimensions: 12 feet high by 90 feet wide (1,080 square feet)
Coverage: 75% of the façade

The mural on Façade 7 spans 12 feet high by 90 feet wide (1,080 square feet), covering approximately 75% of the south elevation of Building 1880. The mural prominently features a stylized portrait of Albert Einstein, rendered in a mix of blues, reds, dark and light pinks, and yellows, with a black background enhancing contrast and depth in Einstein's facial features. Surrounding the portrait are mathematical equations and scientific symbols, reinforcing his contributions to quantum mechanics and theoretical physics.

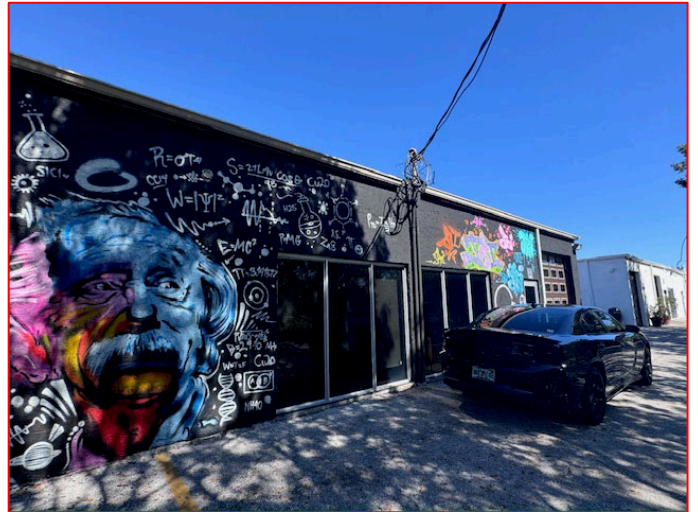

cohesion of the façade.

However, the right portion of the façade previously contained a graffiti-style mural featuring the letters "JRI" and various colorful graffiti tags, which were separate from the Einstein artwork. As seen in the "Before" image, the JRI mural had a distinct composition, with multiple overlapping lettering styles, bright neon colors, and a spray-paint aesthetic, making it stylistically disconnected from the Einstein mural. Since then, the "JRI" graffiti elements have been removed, but their prior existence raises questions regarding compliance and the intended artistic

Per LDR Section 8.5.3(C)(3), *each façade is limited to one mural*, although a consistent image or theme may continue across a contiguous wall. Given the clear stylistic and thematic disconnect between Einstein's portrait and the now-removed graffiti lettering, there is a strong argument that this façade previously contained two separate murals rather than a single, unified artistic statement.

If the graffiti lettering was originally considered a separate artistic installation, it should have required a separate mural permit to comply with the regulations.

While the removal of the "JRI" graffiti elements has improved thematic unity, remnants of the prior mural may still be present, requiring clarification on whether the applicant intends to repaint or restore the affected area. The Public Art Advisory Board must evaluate whether the modifications made to Façade 7 sufficiently align with the original permit request or if additional approvals are necessary.

From an artistic standpoint, the Einstein mural demonstrates a high level of technical skill, particularly in its use of color gradients, lighting effects, and expressive detailing. The mathematical notations and scientific symbols add a layer of intellectual depth, reinforcing Einstein's legacy as a physicist. However, the black background and exposed location raise concerns about long-term maintenance, as dark paint is prone to fading and accumulating dirt. The vibrant colors in Einstein's face may also be susceptible to sun exposure, requiring periodic restoration. A clear maintenance plan must be in place to ensure the mural retains its visual quality over time.

Overall, while the Einstein portion of the mural meets the artistic and thematic criteria of public art, the previous presence of the "JRI" graffiti mural raises compliance concerns. The Board must determine whether the removal of the graffiti elements sufficiently resolves the issue or if further action is needed to ensure full regulatory alignment with mural permit requirements.

Building 1880 Façade 8 (File No. 2025-019)

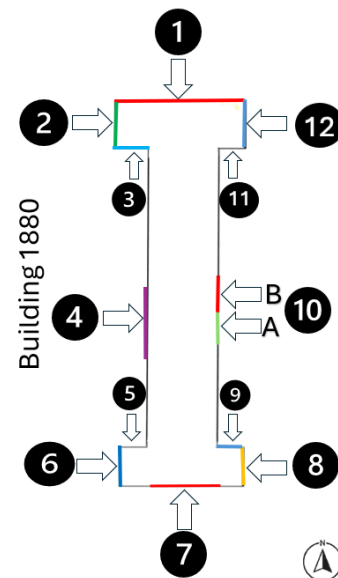

Dimensions: 12 feet high by 30 feet wide (360 square feet)
Coverage: 100% of the façade

The mural on Façade 8 spans 12 feet high by 30 feet wide (360 square feet), covering 100% of the east elevation of Building 1880. The mural features portraits of four prominent historical figures, each depicted in a distinct background color—blue, pink, green, and yellow—creating a visually striking composition. The subjects appear to be individuals of great cultural and historical significance, symbolizing leadership, activism, and justice.

From an artistic standpoint, the mural demonstrates strong composition and technical skill, particularly in its use of bold color blocking and expressive brushwork to capture the likeness of each figure. The choice of vivid, contrasting colors enhances the mural's visual

impact and thematic clarity, ensuring that each figure stands out while maintaining a sense of cohesion within the overall piece. The stylized rendering of facial features and clothing details contributes to the mural's recognizability and cultural depth.

However, while the mural meets artistic and regulatory standards, maintenance concerns arise due to its exposed location and bold color palette. The intensity of the colors may be susceptible to fading, particularly under direct sunlight, which could diminish the mural's vibrancy over time. Additionally, the paint application appears to extend around building elements such as pipes and window edges, which may result in wear and inconsistencies if the mural is not properly sealed or maintained.

Building 1880 Façade 9 (File No. 2025-020)

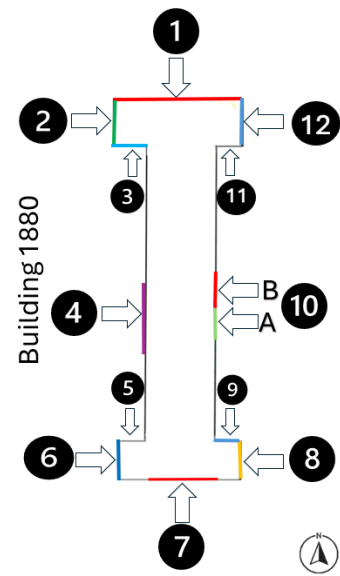

Dimensions: 12 feet high by 20 feet wide (240 square feet)
Coverage: 100% of the façade

The mural on Façade 9 spans 12 feet high by 20 feet wide (240 square feet), covering 100% of the east elevation of Building 1880, located on the south portion of the building facing north. The artwork consists of a combination of abstract patterns, digital-inspired graphics, and text elements on a black background, incorporating symbols, graphs, flowcharts, and interconnected nodes that resemble social media networks, digital interaction, and technological themes.

While the mural presents an intriguing visual approach, its composition appears fragmented, lacking a clear focal point or cohesive artistic narrative. The scattered arrangement of symbols and text results in a disorganized aesthetic, making it challenging to interpret as a unified artistic expression. The inclusion of words such as "Interaction," "Identity," "Subscribers," and "Rank Social"

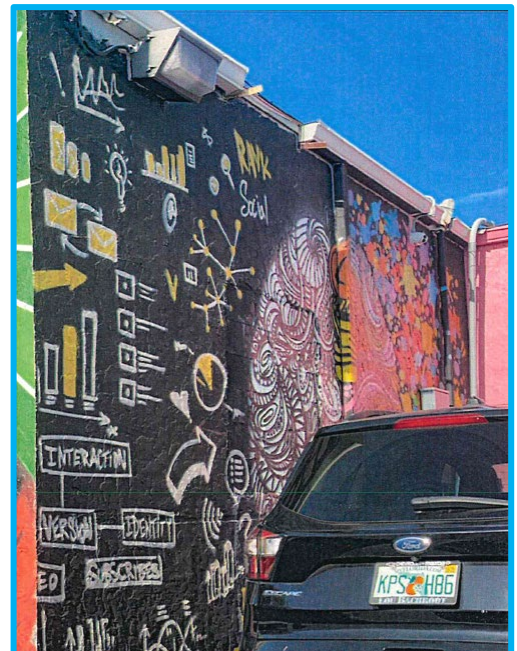

raises concerns regarding potential thematic ambiguity, as the mural blurs the line between conceptual art and informational design.

Per LDR Section 8.5.3(C)(3), each façade is limited to one mural, and while this piece appears to be a single composition, the varied design elements and scattered text create an unstructured visual hierarchy, potentially diminishing its effectiveness as a public art installation. Additionally, the text components must comply with LDR Section 8.5.3(C)(4), which limits text in murals to no more than 5% of the overall mural size, unless incorporated as part of a graphic design. The prominent use of words and labels throughout the mural may exceed this limit.

From a technical perspective, the use of a black background raises durability concerns, as dark colors are prone to fading, accumulating dirt, and showing signs of wear more quickly than lighter hues. The presence of detailed line work and small-scale text elements further increases the risk of deterioration, particularly in high-exposure areas. Without a structured maintenance plan, portions of the mural may fade unevenly, compromising its readability and artistic impact.

Overall, while the mural aligns with the definition of public art under Appendix A of the LDRs, its lack of a cohesive composition, potential text compliance issues, and long-term durability concerns warrant further evaluation by the Public Art Advisory Board. The Board should assess whether modifications are necessary to enhance the mural's thematic clarity, ensure text compliance, and establish a maintenance strategy that preserves the integrity of the artwork over time.

Building 1880 Façade 10A (File No. 2025-021)

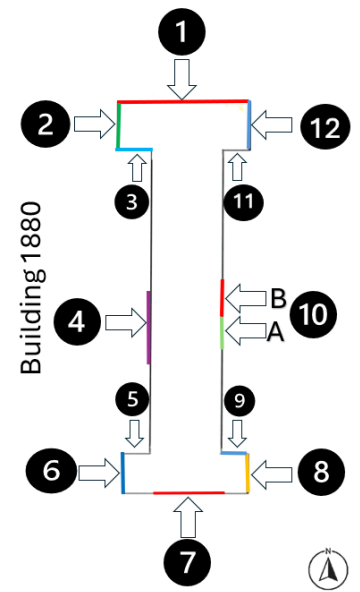

Dimensions: 12 feet high by 5 feet wide; 8 feet by 5 feet above window (100 square feet)

Coverage: 100% of the façade

The mural on Façade 10A spans 12 feet high by 5 feet wide, with an additional 8 feet by 5 feet section above a window (100 square feet total), covering 100% of the east elevation of Building 1880. The "Before" image of the mural featured a prominent symbolic eye with colorful detailing, surrounded by various inspirational hashtags and phrases promoting self-love, empowerment, and positivity. The background consisted of a pastel gradient, blending pink, teal, and white tones to create a visually soft yet impactful message.

The "After" image shows significant alterations to the façade, with most of the previous mural removed or painted over in a muted blue tone. The eye motif remains faintly visible, but the text-heavy content and hashtag phrases have been eliminated. The visual impact of the façade has been greatly reduced, shifting from a message-driven artistic piece to a more subdued color transition with minimal remaining design elements.

Per LDR Section 8.5.3(C)(4), *text within a mural shall be predominantly pictorial, with written elements limited to no more than 5% of the overall mural size, except for text incorporated as a graphic element.* The "Before" version of this mural likely exceeded this limitation, as the hashtags and phrases dominated the composition, making the façade more of a message board than a pictorial mural. The removal of the text components in the "After" image aligns the artwork more closely with mural regulations, ensuring compliance with the LDR.

From a design perspective, the original mural featured a clear theme centered on personal empowerment and positivity, with text playing a dominant role in conveying the message. However, its text-heavy nature and reliance on hashtags may have contributed to a commercialized or promotional aesthetic, blurring the line between public art and branding. The simplified "After" version, while compliant, now appears incomplete and lacks the previous vibrancy and thematic clarity.

Overall, the modifications to Façade 10A have addressed prior compliance issues related to text size and mural definition. However, the altered version now lacks the thematic impact of the original, and its partial removal raises questions about the intended final state of the façade. The Board may need clarification on whether this façade is considered finalized or if further mural work is planned to ensure artistic and regulatory alignment.



Building 1880 Façade 10B (File No. 2025-022)

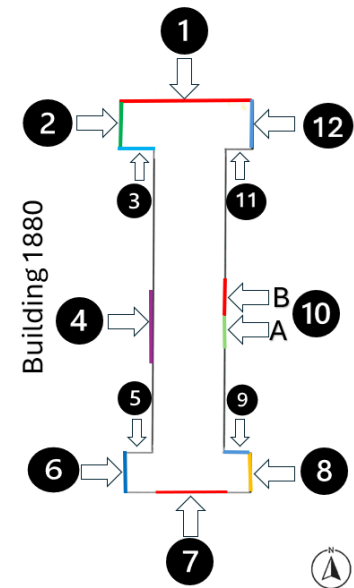

Dimensions: 12 feet high by 20 feet wide (240 square feet)
Coverage: 100% of the façade

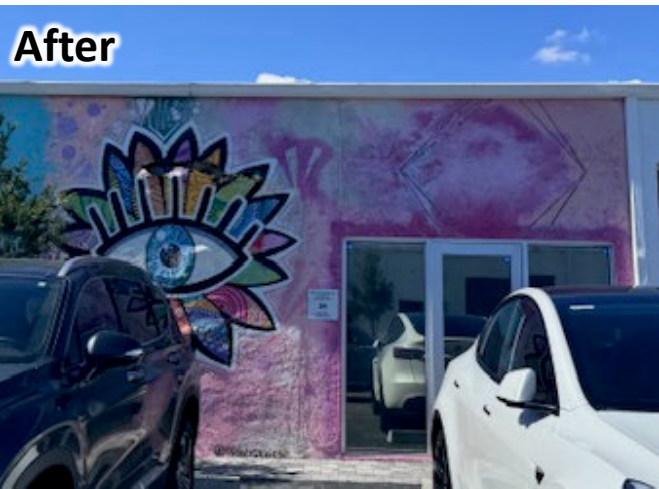

The mural on Façade 10B spans 12 feet high by 20 feet wide (240 square feet), covering 100% of the east elevation of Building 1880. The "Before" image showcases a bold, colorful eye symbol within a lotus-like design, accompanied by text elements, including "ZEK BROWS Studio" and the phrase "#youareenough". The background is a gradient of pink and teal tones, incorporating soft abstract textures and faint images of faces within the design.

The "After" image reveals a significant reduction in mural content, with the studio branding and much of the text removed. The eye design remains, but it appears more faded, and the background has been muted, leaving only faint traces of the previous artwork. The erasure of text and branding elements aligns the mural with regulatory requirements but also results in a loss of vibrancy and thematic clarity.

Per LDR Section 8.5.3(C)(4), *text within a mural shall be predominantly pictorial, with written elements limited to no more than 5% of the overall mural size, except for text incorporated as a graphic element.* The "Before" version likely exceeded this threshold, as both hashtags and business-related text were dominant features. The removal of commercial references ensures compliance with mural

regulations, as business signage must be reviewed under LDR Section 4.6.7, which governs signage regulations separately from murals.

The altered mural now appears faded and incomplete, raising aesthetic concerns regarding its maintenance and artistic integrity. The remaining elements lack the boldness and definition of the original piece, making it unclear whether this is a final iteration or if additional refinements are intended. The faint outlines of the former design suggest an incomplete removal, which may require further intervention to either restore the remaining artwork or repaint the façade entirely.

From a technical standpoint, the pastel background is highly susceptible to fading and weather-related wear, particularly given its prominent exposure. The inconsistent fading and residual ghosting of the prior design create an unfinished appearance, which could diminish the overall aesthetic quality of the building's exterior. The lack of a clear preservation plan for the altered mural may result in further deterioration, necessitating a defined maintenance strategy to prevent further decline.

Overall, while the removal of non-compliant text and branding elements ensures LDR compliance, the resulting mural appears diminished in both impact and artistic execution. The Public Art Advisory Board may need clarification on whether the current version is final or if additional restoration efforts are planned to enhance cohesion, durability, and visual appeal.

Again, the submitted maintenance plan proves to be ineffective and not implemented by the property management thus, not meeting the criteria number 3, 4, and 8 listed in LDR Section 8.5.2(A), criteria for board action.

Building 1880 Façade 12 (File No. 2025-023)

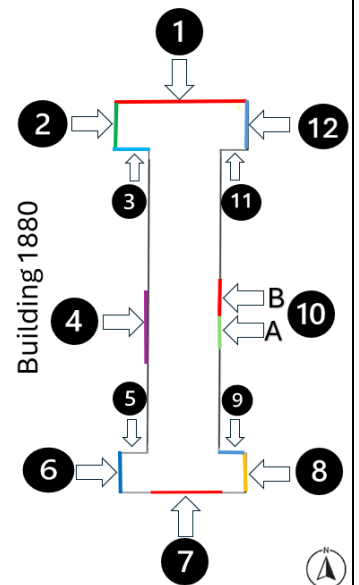

Dimensions: 12 feet high by 30 feet wide (360 square feet)
Coverage: 100% of the façade

The mural on Façade 12 spans 12 feet high by 30 feet wide (360 square feet), covering 100% of the east elevation of Building 1880. It is a highly detailed composition incorporating multiple cultural and historical references, including a stylized portrait of a geisha, a depiction of Dr. Martin Luther King Jr. speaking into a microphone, interlocked hands of different skin tones symbolizing unity, the Statue of Liberty with an American flag overlay, and a red and white flag reminiscent of Puerto Rico or Cuba. The background features graffiti-style lettering, abstract patterns, and vibrant color blocking.

The "Before" image of the mural exhibited bright, saturated colors with well-defined contrasts, while the "After" image shows significant fading and deterioration, particularly in areas where paint appears to have chipped or worn away. The once-bold features of the geisha, hands, and Statue of Liberty are now muted, reducing the visual impact and clarity of the composition. The fading has also affected the graffiti-style text and abstract elements, causing a loss of depth and vibrancy.

Per LDR Section 8.5.3(C)(3), *each façade is limited to one mural*, though a consistent image or theme may continue across contiguous walls. This mural qualifies as a single, cohesive artistic statement, successfully integrating multiple cultural and historical references into one narrative of unity and resilience. However, the noticeable deterioration raises concerns regarding maintenance and longevity, which must be addressed per LDR Section 8.5.3(C)(7), requiring a preservation and maintenance plan to ensure the mural retains its integrity.

Additionally, LDR Section 8.5.2(A)(4) requires public art to be of exceptional quality and enduring value. While the original execution demonstrated a high level of artistry, the current condition suggests inadequate maintenance, which could diminish its intended long-term cultural and aesthetic contribution. The Public Art Advisory Board may need further clarification on restoration efforts or protective measures planned to prevent further degradation.

From a technical standpoint, the vivid color palette and intricate details require a stable surface and proper protective coatings to prevent fading, chipping, and weather-related wear. Without proactive upkeep, the mural risks further loss of detail and artistic impact over time. The Board should assess whether the existing maintenance plan is sufficient or if additional measures, such as resealing and periodic touch-ups, should be mandated.

Overall, while Façade 12's mural meets artistic and thematic criteria for public art, its current state of deterioration raises significant maintenance concerns. The Board must determine whether restoration efforts should be required to preserve its cultural significance, artistic integrity, and compliance with mural preservation standards.

Mural Analysis

A thorough analysis of each mural is provided in the individual mural reviews. There are specific criteria for the Board to consider when taking action on mural requests. The following board criteria and technical criteria are listed below.

LDR Section 8.5.2(A) – Criteria for Board Action.

The following guidelines are to be utilized when making a recommendation or acting on a request for the installation of public art, whether located on private or public property: If the following criteria are not met, the application shall be disapproved:

- (1) *Whether the proposed public art conforms to the definition of public art;*
- (2) *Whether the proposed public art is compatible with the neighborhood and not injurious to the neighborhood or otherwise detrimental to the public welfare;*
- (3) *Whether the proposed public art presents a safety hazard to the public;*
- (4) *Whether the proposed public art is of exceptional quality and enduring value;*
- (5) *Whether the proposed public art serves to further the City's goal of promoting cultural diversity;*
- (6) *Whether the proposed public art is appropriate to the site;*
- (7) *Whether the proposed public art should be installed at the proposed location on a site or at a different location;*
- (8) *Whether the proposed public art requires extraordinary maintenance, such as any special servicing due to periodic adjustment, repairing, or repair or replacement of moving parts.*
- (9) *Whether the proposed public art conforms with all other applicable aspects of the LDRs.*

The following analysis is provided that includes the board criteria listed above, and the technical criteria listed below.

LDR Section 8.5.3(A), Location

Murals may be proposed on a façade, flat top roof, parking deck, perimeter walls or fences, or dumpster enclosures of any building or structure on a property not located in a historic district or individually designated on the Local Register of Historic Places but that:

- (a) *Faces a railroad right-of-way;*
- (b) *Faces Interstate 95;*

(c) Is located within the Central Business District (CBD), Community Facilities (CF), Industrial (I), Light Industrial (LI), Mixed Industrial and Commercial (MIC), **Mixed Use Residential Office and Commercial (MROC)**, General Commercial (GC), Planned Commercial (PC), Neighborhood Commercial (NC), Planned Office Commercial (POC), Professional Office District (POD), Open Space and Recreation (OSR), or Special Activities District (SAD) zoning districts.

The subject property is located within the MROC zoning district and features a warehouse building, specifically Building 1878. Although this building does not directly face either a railroad right-of-way or Interstate 95, the property in its entirety does front the FEC Railway and Interstate 95 is directly to the east of the railway.

LDR Section 8.5.3(B), Design and installation

Each mural shall be designed and installed with techniques and/or materials that do not permanently damage the facade of the building. Murals are also subject to compliance with the applicable requirements of the Florida Building Code any other applicable local, state, or federal regulations.

LDR Section 8.5.3(C), Placement and Design requirements

All murals must meet the following requirements:

- (1) **Coverage, size, and scale.** Murals shall be proportionate in size and scale to the building facade. A mural may cover 100 percent of the wall, provided it does not paint over windows.
- (2) **Façade features.** Murals shall be positioned on the façade in a manner that respects architectural features. Murals shall not cover windows or mask architectural details in a manner that detracts from the architecture of the building.
- (3) **Mural limitations.** Each facade or surface of a building or accessory structure shall have only one mural. A consistent image or theme may continue across contiguous walls; however, each facade or surface included in the mural shall require a separate mural permit.
- (4) **Mural text size.** The mural shall be predominantly pictorial, with text limited to no more than 5 percent of the proposed mural size, **except for text used to create the graphic.**
- (5) **Signage and commercial messaging.** Signage and commercial messaging in murals are regulated in accordance with Section 4.6.7.
- (6) **Illumination.** Murals may be illuminated only by indirect lighting. Any proposed illumination shall be accompanied by a photometric plan as set forth in Section 2.4.3(B)(17) that demonstrates compliance with Section 4.6.8. Illumination shall not continue after 11:00 pm. Internal illumination, blinking lights, and flashing lights are prohibited.
- (7) **Preservation and maintenance.** Applicants must provide a preservation and maintenance plan for the proposed mural.
- (8) **Public safety.** Mural faces may not have any moving or animated parts, or any other electronic movements. Murals may not be illuminated in such a manner so as to cause glare or to impair the vision of motorists or otherwise distract motorists and interfere with their ability to safely operate their vehicles.
- (9) **Compliance with laws.** Murals must comply with all applicable laws, rules and regulations of the federal, state and county governments. Any proposed amendments to this section must be consistent with applicable federal, state and county laws and ordinances in effect at the time of such amendment.

Appendix A of the LDR defines a “mural” as “an original, one-of-a-kind unique mosaic, painting, or graphic art or combination thereof (including collage effects) that is professionally applied to aesthetically enhance the exterior of a building or accessory structure such as a dumpster enclosure, fence, or site wall, **that does not contain any brand name, product name, letters of the alphabet spelling or abbreviating the name of any product, company, profession, or business, or any logo, trademark, trade name, or other commercial message.**”

The mural regulations allow text on murals provided that the text size does not exceed 5% of the total mural size and meets the definition of a mural.

In addition, Appendix A provides a definition of a “**painted wall sign**” which is defined as “a sign applied with paint or similar substance on the face of a wall.” Furthermore, a “**wall sign**” is defined as “a sign painted or attached parallel to the outside of a building”. Therefore, any letters applied by paint are considered a wall sign and shall be subject to the Sign Code regulations set forth in Section 4.6.7.

Pursuant to Table 4.6.7(A), Sign standards per zoning district, the MROC zoning district allows various sign types. One type of signage allowed is a wall sign which is restricted to one wall sign per business that faces a dedicated street frontage or facing I-95 and one wall sign per building restricted to 9 square feet to the rear of the building not facing a street. As the subject property does not face any streets or I-95, the subject property is limited to only one wall sign per building, not including the other various sign types such as directory, projecting, under canopy or free-standing sign.

The applicant has provided a detailed maintenance plan for the murals, which includes biannual visual assessments to check for signs of fading, chipping, cracking, vandalism, or other damages. In addition, minor repairs will be addressed promptly with touch-ups for fading, damage or vandalism within 72 hours of identification. The maintenance plan also outlines an annual cleaning schedule for removing dirt, dust, and pollutants from all murals, with a protective clear coat or sealant reapplied to safeguard the murals against environmental factors. The proposed murals do not include any electronic components, animated parts or any illumination that would cause glare to impair or distract the vision of motorists from the ability to safely operate their vehicle

The murals were the creation of Denny Graff, an established artist with experience in graffiti art, murals, acrylic painting, and design. His work can be found in prominent locations like Orlando and Wynwood. He began as a graffiti artist on the streets. He is known for his unique ability to blend urban grit with contemporary art. Graff's comprehensive Biography is attached.

Overall, Andre Design District has a total of 31 existing murals spread across four warehouse buildings, illustrating various murals. Per Appendix A of the LDRs, “**Public Art**” is defined as “a means of artwork or works of art including, but not limited to sculptures, integrated architectural or landscape architectural work, community art, digital media installations, or murals....”

The subject property is surrounded by industrial use to the north and the County's Administrative Complex to the west and south within the Congress Avenue Corridor with a Congress Avenue Mixed Use (CMU) land use designation. The vision for the Congress Avenue Corridor is to offer new development and redevelopment with a mix of commercial, industrial, office, and residential uses with a cohesive aesthetic for the corridor.

Objective NDC 1.4 Industrial Land Use Designations

Apply the industrial land use designations of Industrial and Commerce to those areas where industrial type uses, such as fabrication and assembly of goods, warehousing, and vehicle repair, are the primary economic strategy for the district, to ensure that those industries, which are essential to the local economy, are appropriately accommodated in the city.

Policy NDC 1.4.9

Analyze the existing land use and zoning designations of Commerce and Congress Avenue Mixed Use assigned to property along the Congress Avenue Corridor for the purpose of accommodating a balanced mix of commercial, industrial, office, and residential uses with a cohesive aesthetic for the corridor.

OBJECTIVE HCE 3.6 Design & Social Interaction

Encourage new developments to promote social interaction through site design.

Policy HCE 3.6.3

Encourage the provision of public art and preserve and increase access to cultural resources.

A similar redevelopment strategy has been taking wave through industrial zoned districts such as Wynwood in Miami to revitalize the neighborhood after a mass exodus of residents leaving behind abandoned warehouses. The transformation began for the neighborhood in the early 2000s by a real estate developer who bought the properties. Wynwood has since evolved into one of the most prominent creative communities in the United States, and a global

destination for art, fashion, and innovation.

In 2019, the current property owner acquired the four buildings with a vision to transform them into Delray's next hub for local businesses, galleries and restaurants which are permitted uses within the MROC zoning district. The purpose was to attract the public to the "off the beaten path" offering a unique mix of businesses known as "The Andre Design District". At that time, the commissioning of the existing murals existing today was pursued.

The Comprehensive Plan highlights the importance of allowing public art, preserving and increasing access to cultural resources. It promotes strategic partnerships with those involved with the creative arts to establish policies and programs that enhance Delray Beach as a diverse City through cultural attractions, traditions, communities and business districts. The plan also identifies synergies between these clusters of cultural and innovation districts to encourage economic development in mixed use centers and neighborhoods.

Delray Beach is rich in cultural history, and the vision for the city includes preserving the existing cultural districts, market and brand cultural attractions and traditions. Meanwhile, identifying new opportunities for additional cultural district, allow public arts and expand by creating innovation districts to grow the clusters to create economic prosperity in mixed use centers and neighborhoods.

The creation of a new cultural or innovation district through the commissioning of these murals in the "Andre Design District" aligns with the vision of the Comprehensive Plan provided that this initiative improves the quality of life of Delray Beach residents.

The Board shall consider whether the proposed public art is compatible with the surrounding neighborhood, created with exceptional quality and enduring value that serves the City's goal of promoting cultural diversity and identifies as an opportunity to create an innovation district to grow and encourage economic development. The Board shall also consider if the expansion of the public art which is typically found downtown is appropriate to this site or should be located at a different location. Additionally, the Board shall consider if the 2 existing murals on the east elevation on façade 10A and 10B constitute separate images or form one consistent theme or image or meets the definition of a mural. The Board shall further consider the existing non-compliant signage incorporated into the existing murals and the deteriorated and peeling murals for action.

Objective SPE 2.1 Private and Nonprofit Organizations

Increase efforts to build new public-private partnerships and expand existing partnerships to improve the quality of life for Delray Beach residents.

Policy SPE 2.1.9

Coordinate with private partners involved in the creative arts to establish policies and programs in building a cultural master plan. [Complete by 2025]

Objective ECP 3.2 Cluster Marketing

Market and brand Delray Beach focused on the synergies of its industry clusters.

Policy ECP 3.2.6

Promote Delray Beach as a diverse city highlighting cultural attractions, traditions and communities in neighborhoods and business districts as well as downtown.

Policy ECP 3.3.2

Identify opportunities for potential zones, cultural districts or innovation district to grow the clusters and encourage economic development in mixed-use centers and neighborhoods.

Optional Board Actions

Façade 1 (File No. 2025-015)

- A. Move approval, of the Mural Permit (2025-015) to paint a mural (façade 1) on the north elevation of Building 1880 located at **1880 Dr. Andre's Way**, by finding that the request is consistent with the Comprehensive Plan and meets criteria set forth in Chapter 8 of the Land Development Regulations.
- B. Move approval, as amended, of the Mural Permit (2025-015) to paint a mural (façade 1) on the north elevation of Building 1880 located at **1880 Dr. Andre's Way**, by finding that the request is consistent with the Comprehensive Plan and meets criteria set forth in Chapter 8 of the Land Development Regulations.
- C. Move denial, of the of the Mural Permit (2025-015) to paint a mural (façade 1) on the north elevation of Building 1880 located at **1880 Dr. Andre's Way**, by finding that the request is consistent with the Comprehensive Plan and meets criteria set forth in Chapter 8 of the Land Development Regulations
- D. Postpone

Façade 3 (File No. 2025-016)

- A. Move approval, of the Mural Permit (2025-016) to paint a mural (façade 3) on the west elevation of Building 1880 located at **1880 Dr. Andre's Way**, by finding that the request is consistent with the Comprehensive Plan and meets criteria set forth in Chapter 8 of the Land Development Regulations.
- B. Move approval, as amended, of the Mural Permit (2025-016) to paint a mural (façade 3) on the west elevation of Building 1880 located at **1880 Dr. Andre's Way**, by finding that the request is consistent with the Comprehensive Plan and meets criteria set forth in Chapter 8 of the Land Development Regulations.
- C. Move denial, of the of the Mural Permit (2025-016) to paint a mural (façade 3) on the west elevation of Building 1880 located at **1880 Dr. Andre's Way**, by finding that the request is consistent with the Comprehensive Plan and meets criteria set forth in Chapter 8 of the Land Development Regulations
- D. Postpone

Façade 6 (File No. 2025-017)

- A. Move approval, of the Mural Permit (2025-017) to paint a mural (façade 6) on the west elevation of Building 1880 located at **1880 Dr. Andre's Way**, by finding that the request is consistent with the Comprehensive Plan and meets criteria set forth in Chapter 8 of the Land Development Regulations.
- B. Move approval, as amended, of the Mural Permit (2025-017) to paint a mural (façade 6) on the west elevation of Building 1880 located at **1880 Dr. Andre's Way**, by finding that the request is consistent with the Comprehensive Plan and meets criteria set forth in Chapter 8 of the Land Development Regulations.
- C. Move denial, of the of the Mural Permit (2025-017) to paint a mural (façade 6) on the west elevation of Building 1880 located at **1880 Dr. Andre's Way**, by finding that the request is consistent with the Comprehensive Plan and meets criteria set forth in Chapter 8 of the Land Development Regulations
- D. Postpone

Façade 7 (File No. 2025-218)

- A. Move approval, of the Mural Permit (2025-218) to paint a mural (façade 7) on the south elevation of Building 1880 located at **1880 Dr. Andre's Way**, by finding that the request is consistent with the Comprehensive Plan and meets criteria set forth in Chapter 8 of the Land Development Regulations.
- B. Move approval, as amended, of the Mural Permit (2025-218) to paint a mural (façade 7) on the south elevation of Building 1880 located at **1880 Dr. Andre's Way** by finding that the request is consistent with the Comprehensive Plan and meets criteria set forth in Chapter 8 of the Land Development Regulations.
- C. Move denial, of the of the Mural Permit (2025-218) to paint a mural (façade 7) on the south elevation of Building 1880 located at **1880 Dr. Andre's Way**, by finding that the request is consistent with the Comprehensive Plan and meets criteria set forth in Chapter 8 of the Land Development Regulations
- D. Postpone

Façade 8 (File No. 2025-019)

- A. Move approval, of the Mural Permit (2025-019) to paint a mural (façade 8) on the east elevation of Building 1880 located at **1880 Dr. Andre's Way**, by finding that the request is consistent with the Comprehensive Plan and meets criteria set forth in Chapter 8 of the Land Development Regulations.

- B. Move approval, as amended, of the Mural Permit (2025-019) to paint a mural (façade 8) on the east elevation of Building 1880 located at **1880 Dr. Andre's Way**, by finding that the request is consistent with the Comprehensive Plan and meets criteria set forth in Chapter 8 of the Land Development Regulations.
- C. Move denial of the Mural Permit (2025-019) to paint a mural (façade 8) on the east elevation of Building 1880 located at **1880 Dr. Andre's Way** by finding that the request is consistent with the Comprehensive Plan and meets criteria set forth in Chapter 8 of the Land Development Regulations
- D. Postpone

Façade 9 (File No. 2025-020)

- A. Move approval, of the Mural Permit (2025-020) to paint a mural (façade 9) on the east elevation of Building 1880 located at **1880 Dr. Andre's Way**, by finding that the request is consistent with the Comprehensive Plan and meets criteria set forth in Chapter 8 of the Land Development Regulations.
- B. Move approval, as amended, of the Mural permit (2025-020) to paint a mural (façade 9) on the east elevation of Building 1880 located at **1880 Dr. Andre's Way**, by finding that the request is consistent with the Comprehensive Plan and meets criteria set forth in Chapter 8 of the Land Development Regulations.
- C. Move denial of the Mural Permit (2025-020) to paint a mural (façade 9) on the east elevation of Building 1880 located at **1880 Dr. Andre's Way** by finding that the request is consistent with the Comprehensive Plan and meets criteria set forth in Chapter 8 of the Land Development Regulations.
- D. Postpone

Façade 10A (File No. 2025-021)

- A. Move approval, of the Mural Permit (2025-021) to paint a mural (façade 10A) on the east elevation of Building 1880 located at **1880 Dr. Andre's Way**, by finding that the request is consistent with the Comprehensive Plan and meets criteria set forth in Chapter 8 of the Land Development Regulations.
- B. Move approval, as amended, of the Mural Permit (2025-021) to paint a mural (façade 10A) on the east elevation of Building 1880 located at **1880 Dr. Andre's Way**, by finding that the request is consistent with the Comprehensive Plan and meets criteria set forth in Chapter 8 of the Land Development Regulations.
- C. Move denial of the Mural Permit (2025-021) to paint a mural (façade 10A) on the east elevation of Building 1880 located at **1880 Dr. Andre's Way**, by finding that the request is consistent with the Comprehensive Plan and meets criteria set forth in Chapter 8 of the Land Development Regulations.
- D. Postpone

Façade 10B (File No. 2025-022)

- A. Move approval, of the Mural Permit (2025-022) to paint a mural (façade 10B) on the east elevation of Building 1880 located at **1880 Dr. Andre's Way**, by finding that the request is consistent with the Comprehensive Plan and meets criteria set forth in Chapter 8 of the Land Development Regulations.
- B. Move approval, as amended, of the Mural Permit (2025-022) to paint a mural (façade 10B) on the east elevation of Building 1880 located at **1880 Dr. Andre's Way** by finding that the request is consistent with the Comprehensive Plan and meets criteria set forth in Chapter 8 of the Land Development Regulations.

C. Move denial of the Mural Permit (2025-022) to paint a mural (façade 10B) on the east elevation of Building 1880 located at **1880 Dr. Andre's Way** by finding that the request is consistent with the Comprehensive Plan and meets criteria set forth in Chapter 8 of the Land Development Regulations.

D. Postpone

Façade 12 (File No. 2025-023)

A. Move approval, of the Mural Permit (2025-023) to paint a mural (façade 12) on the east elevation of Building 1880 located at **1880 Dr. Andre's Way**, by finding that the request is consistent with the Comprehensive Plan and meets criteria set forth in Chapter 8 of the Land Development Regulations.

B. Move approval, as amended, of the Mural Permit (2025-023) to paint a mural (façade 12) on the east elevation of Building 1880 located at **1880 Dr. Andre's Way** by finding that the request is consistent with the Comprehensive Plan and meets criteria set forth in Chapter 8 of the Land Development Regulations.

C. Move denial of the Mural Permit (2025-023) to paint a mural (façade 12) on the east elevation of Building 1880 located at **1880 Dr. Andre's Way**, by finding that the request is consistent with the Comprehensive Plan and meets criteria set forth in Chapter 8 of the Land Development Regulations.

D. Postpone